

# Electric Quarter Turn Actuator

PSR-E-C25

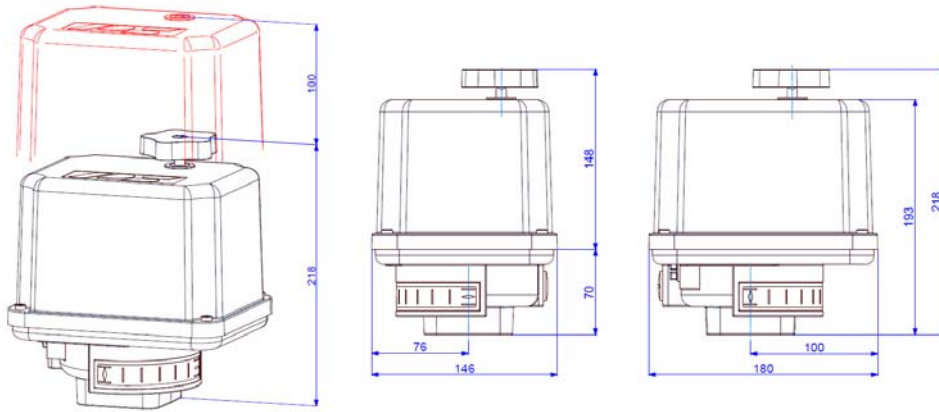

weight: approx. 3 kg without accessories

**25 Nm max. Torque**

13 Nm running torque )<sup>1</sup>

**17 s**

Operating time/90° at 50 Hz

Flange F04 F05 F07\*  
acc. to ISO 5211

Actuator Class C  
acc. to DIN EN ISO 22153

**Enclosure IP65**

acc. to EN 60529

Operating Time/90°	17 s [50 Hz] / 14 s [60 Hz]				9 s
Power Supply [V]	230 VAC 1~	115 VAC 1~	24 VAC 1~	400 V 3~	24 VDC
Frequency [Hz]	50 / 60	50 / 60	50 / 60		
Nominal Current [A]	0.05	0.13	0.6		
Maximum Current [A]	0.06	0.15	0.73		
Power Consumption ) <sup>2</sup> [W]	12	15	15		

Standard Equipment					
Duty Cycle IEC 60034-1,8	S2 - 20 min, S3/S4 - 1200 c/h - 50% at 25°C				
Ambient Temperature [°C]	-25 at +70 (S2) / -20 at +60 (S4)				
Motor Protection	Thermo switch				
Overvoltage Category	II				
Drive Bush	17 mm double square, drawing see back side				

Accessories/Options	230 VAC 1~	115 VAC 1~	24 VAC 1~	400 V 3~	24 VDC
Position Signal Switches 2WE	•	•	•		
Position Signal Switches 2WE Gold	•	•	•		
Position Transmitter PSPT	• ) <sup>3</sup>	• ) <sup>3</sup>	• ) <sup>3</sup>		
Valve Positioner Function PSAP	•	•	• ) <sup>4</sup>		
Heating Resistor ) <sup>5</sup> HR	•	•	•		
Potentiometer PD	•	•	•		
Adapter for Valve Shaft	Options on request				
Increased Enclosure IP	Increase of enclosure to IP67				

PSR-E-C  
25 Nm

For more information and accessories, please visit our website [www.ps-automation.com](http://www.ps-automation.com)!

\* Flange details see back side

• = available, for further information please check the data sheet

)<sup>1</sup> = Permissible average torque over the travel of 90°

)<sup>2</sup> = at maximum torque and 50 Hz

)<sup>3</sup> PSPT02: 2-wire technology; PSPT03: 3-wire technology

)<sup>4</sup> = PSAP with external relay required (version .../R)

)<sup>5</sup> = Supply voltage 24 V or 115-230 V

## Electric Wiring Diagram

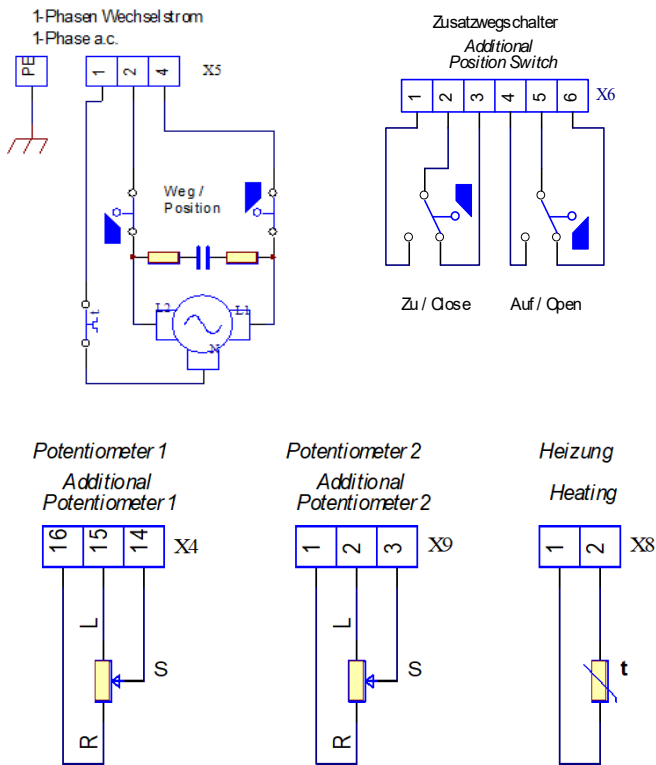

## ISO Flange Dimensions

ISO 5211	F04/07	F05/07
M	M5/M6	M5/M8
B	8/9 mm	8/12 mm

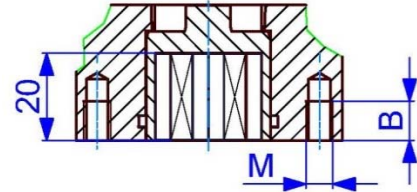

## Dimensions for Drive Bushes

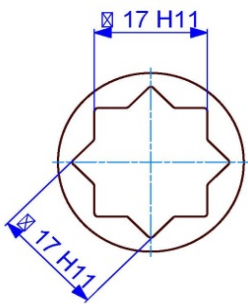

Please check drive bushes datasheet for available sizes!

Other customized drive bushes on request!

## Mounting Positions

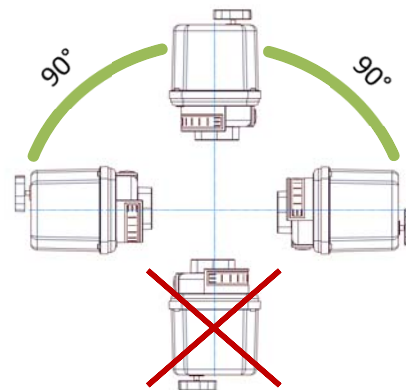

Subject to changes!