

Intelligent Linear Actuator

PSL204AMS12 -40°C

Low Temperature Version

Positioner integrated

3.4 kN

Max. thrust)¹

2.0 - 4.0 mm/s

Operating speed

max. 50 mm

stroke

Modulating actuator

Class C acc. to DIN EN ISO

22153

Enclosure IP65

acc. to EN 60529

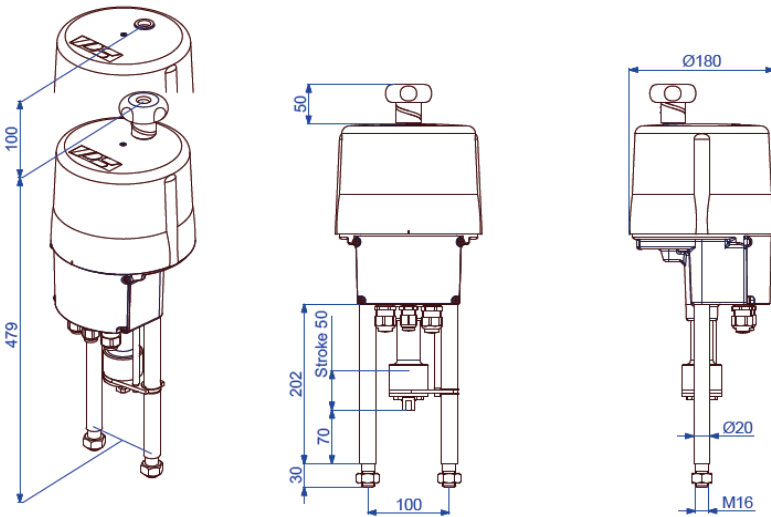

Dimensions are only valid up to and including connection M12!

Approx. weight: 8 kg without accessories

Operating speed	2.0 - 4.0 mm/s (adjustable)			
Power supply [V]	230 VAC 1~	115 VAC 1~	24 VAC/DC	360...575 VAC 3~) ²
Nominal current) ³ [A]	0.33	0.66	3.15(AC) / 2(DC)	
Max. current) ³ [A]	0.43	0.86	4.1(AC) / 2.6(DC)	
Power consumption) ⁴ [W]	57	57	53(AC) / 48(DC)	

**PSL204
AMS12**

Standard	Description
Ambient temperature [°C]	-40 to +60 °C
Motor protection	Electronic motor current monitoring with safety cut-off
Overvoltage category	II
Break away force	Adjustable up to +50% nominal force
Duty cycle IEC 60034-1,8	S2 30 min S4 50% ED @ 25°C
Set value and feedback	0 (4)..20 mA or 0 (2)..10 V selectable, split range operation
Binary control	24 V - 230 V for ON/OFF control (min. duration of pulse 1s)
Valve positioner function	Integrated positioner, deadband adjustable from 0.5 .. 5%, shut-off minimum
Automatic start-up	Recognizing the end position(s) and autoscaling set and feedback values
Internal fault monitoring	Torque, set value, temperature, power supply, positioning deviation etc., adjustable
Fault indication relay FIR	Potential-free opening contact provides a freely definable collective fault signal
Diagnostics function	Stores cumulated operation data (motor and total running time, number of motor starts) and data sets of current values (set value, feedback value, torque, temperature and error messages)
Communication interface	Connecting to a USB port and a software, allows data reading and parametrisation
Cable glands	2 pcs. M20 x 1,5 and 1 pcs. M16 x 1,5

Standard equipment

)¹ = permissible average force over the entire travel is 50% of the max. thrust

)² = max. input voltage range

)³ = data may vary depending on accessories

)⁴ = at max. force, data may vary depending on accessories

Electrical connection plan

1-Phasen Wechselspannung / DC 1-Phase AC / DC																					3-Phasen 3-Phase AC												
1	2	3	4	5	6	7	8	9	10	11	12	13	14	15	16	17	18	19	20	21	22	23	PE	RJ-45 TTL	Taster Button	L1	L2	L3	PE				
↕	↕	↕	↕	↕	↕	↕↔	↕↔	↕	↕	↕	↕	↕	↕	↕	↕	↕	↕↔	↕↔	↕↔	↕↔	↕↔	↕	↕			↕	↕	↕	↕				
+0(2) -10 V	+0(4) -20 mA	GND	+0(2) -10 V	+0(4) -20 mA	GND	max. Last / max. Load 100 mA bei / at 24 VDC		L+ AUF/OPEN	N-	L+ ZU/CLOSE	L+ (24V AC/DC - 230VAC) (Option)	N- (24V AC/DC - 230VAC) (Option)	21 - 40 VDC / 100 mA	+0(2) -10 V	+0(4) -20 mA	GND	(Option)	(Option)	(Option)	(Option)	(Option)	L+ (siehe Typenschild/ see tag plate)	N- (siehe Typenschild/ see tag plate)	PE	(Option)					400 VAC	400 VAC	400 VAC	Schutzleiter / protective conductor
Sollwert-Eingang	Aktive Positionsrückmeldung					Störmeldung potentialfrei		Binäre Ansteuerung		Netz- ausfall- signal	Versor- gung	Istwert				Zu / Closed	Auf / Open	Wegschalter potentialfreier Kontakt			Versorgungs- spannung	Feldbus- Anschluß	PC Kommu- nikation	Inbetrieb- nahme					Versorgungs- spannung				Schaltnetzteil
Set value input	Active position feedback					Monitor relay potential-free		Binary input signals		Fail safe signal	Supply	Actual value				Position switch potential-free contact					Power supply voltage	Fieldbus interface	PC communication	Commissioning					Power supply voltage				
Galvanisch getrennt / Galvanically isolated 1 kV												Process-Sensor										8013770 - S-217_G											

Dimensions of the PS standard adaptation

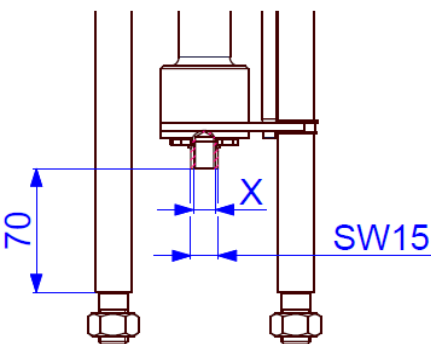

Connection Thread X

M8	Optional
M10	Optional
M12	Standard
M14	Optional
M16	Optional

Fine threaded and other sizes on request!

Mounting position

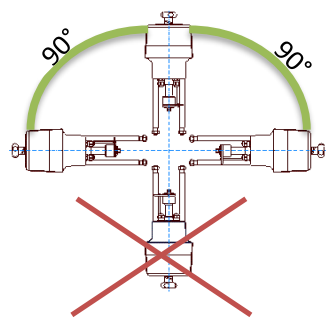

Dimensions are valid for connections M8-M12 only!

Accessories/options			
Add'l position switches	2WE	Potential-free additional position switches with silver contacts (0.1 A - 10 A switching current)	
Add'l position switches gold	2WE Gold	Potential-free additional position switches with gold contacts (0.1 mA - 100 mA switching current)	
Integrated process controller	PSIC	Enables the autonomous control of a process so that an external controller is not required.	
Fail-safe*	PSCP	Emergency power supply based on supercapacitors, safety position OPEN, CLOSED or free defined position	
Fieldbus interface*		Digital transmission of nominal and actual value per mill or percent, report of monitoring and diagnostic data using Profibus DP (PSPDP) or CANOpen (PSCA) interfaces, additional interfaces available on request	
Local control	PSC.2	Illuminated display to show the actuator status and lockable selector to switch between modes: automatic, manual process ON/OFF, STOP and parameter menu. Control buttons for manual movement, menu operation and adjustment of parameters, display of diagnostic information	
Remote local control		Mounting separately from the actuator (incl. 10 m connection cable)	
Data cable	PSCS-USB	USB data cable enables the communication between the actuator and a PC by using the software PSCS	
Fail-safe port*	FSP	Signal port to drive to a "safety position", selectable fail-safe position, standard 24 - 230 V	
IP67		Increased enclosure IP67	
Heating resistor	HR	Heating resistor to prevent condensation	

*not retrofittable

For more information and accessories, please visit our website www.ps-automation.com!

Subject to changes!