

PSQ-E PSR-E

Quarter-turn actuators

25 Nm to 150 Nm



PSQ-E/PSR-E

Quarter-turn actuators

Many applications, especially for 25 Nm to 150 Nm torque, don't require torque switches in order to protect the valve. Instead of using an exchangeable drive bush it is mostly sufficient to fit in a square with reducers for squares or double D.

Options for valve positioners and local control aren't necessary in many applications.

Instead, the focus is on robustness and cost optimisation.

Our development engineers took into account these customer requirements and have designed two very economic series based on our proven PSR und PSQ actuators: PSR-E (25 Nm / 50 Nm) and PSQ-E (100 Nm / 150 Nm).

Engineered and Made in Germany.

Robust metal main frame

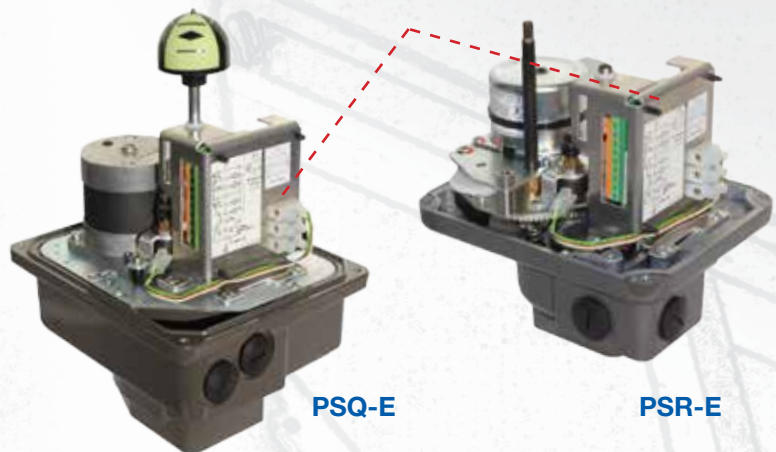

„E“ like Economy: cost-effective, robust and efficient

Our economy series include the quarter-turn actuators PSQ-E and PSR-E and combines robustness and efficiency at an attractive price-performance ratio.

For the **PSQ-E** series we use a very economic manufacturing method and a very efficient overriding drive in order to enable robustness at low cost. The valve is protected by using torque limited motors with thermo switches instead of torque switches.

The quarter-turn actuator series **PSR-E** is the economical addition to the proven actuator series PSQ for torque requirements from 25 Nm to 50 Nm. The PSR-E series contains a maintenance-free, low-wear and low-noise spur gear resulting in high efficiency and long lifetime.

PSQ-E and PSR-E with various operating times are most suitable for control operation due to the use of synchronous motors without after-run. Optionally, users in the shop floors or at the

construction site can retrofit a heating, a potentiometer as well as a mA position transmitter in two- or three-wire technology. Both series can be directly mounted as per ISO 5211.

The standard equipment includes two potential-free change-over contacts which are preset to 0° and 90° travel to signalize the end positions. The cams are continuously adjustable to any intermediate position.

Customers who use the PSQ-E and PSR-E quarter-turn actuators profit from a standardisation of the modular accessories in several ways, as fewer parts must be held in stock and the training requirements for the sales, service and assembly staff are reduced considerably.

Reliable even under harsh conditions

Ideal for industrial environments: cover made of UV-resistant polycarbonate, enclosure IP65, IP67 optional.

Strong and efficient

Maintenance-free, high-efficiency and low-noise spur gear resulting in low-wear and long lifetime.



Comfortable manual override
due to „Push and Turn“.
Automatic re-engagement.

PSR-E



Externally adjustable stop screw
prevents from manual overriding of the closed position.

Easily visible position indicator

Drive bush integrated
Double square drive, size 17 mm in the output wheel (Reduction pieces available for Square/Double D).

Enclosure IP67,
optional IP68,
with metal cover.

Synchronous motor blockable,
integrated thermo switch.

Comfortable manual override
without locking mechanism. The handwheel does not rotate during motor operation.

PSQ-E

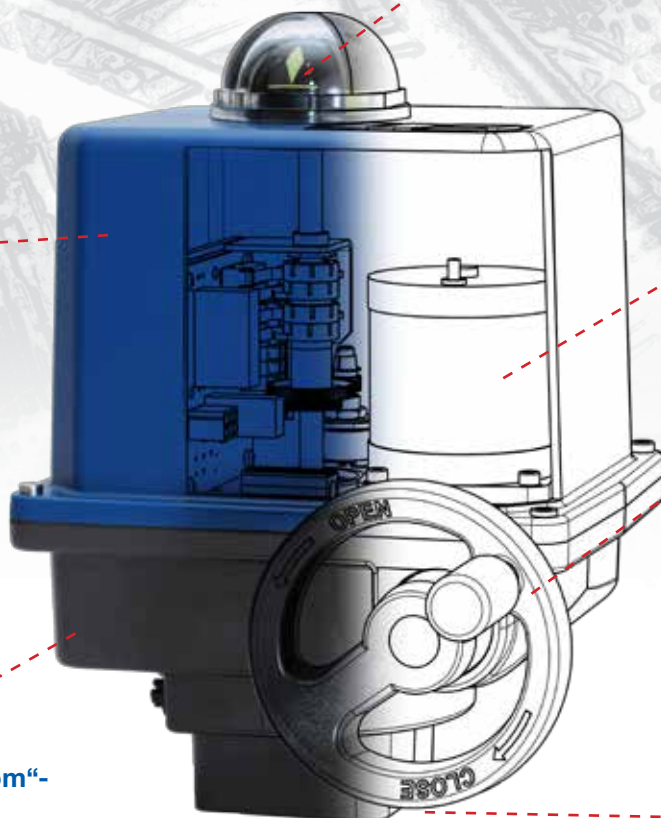

Robust „Wolfrom“-planetary gear
Reduced power consumption due to highly efficient gear.

Drive bush integrated
Double square drive, size 22 mm in the output wheel (Reduction pieces available for Square/Double D).



Standard Equipment

Two economic actuators with added value: The standard equipment of PSQ-E und PSR-E already includes two additional limit switches and a double square drive at no extra cost.

Spring loaded terminals

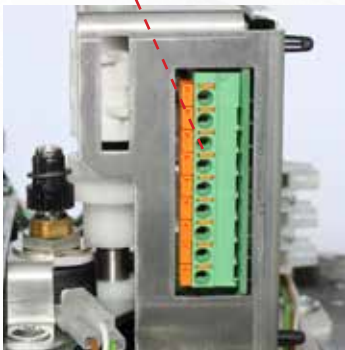

Pre-adjusted switching cams
2x position and
2x signal switches integrated



Double square drive



Accessories/Options

The PSQ-E and PSR-E actuators from PS Automation have a modular concept and are available in many variations; the upgrading with accessories is even possible on site.

The PSQ-E and PSR-E actuators can be adapted to all requirements concerning controlling and regulating material flows, e.g. with the following accessories:

- Single or double potentiometer
- Heating resistor
- Electronic position transmitter PSPT
- Adapter for valve shaft



PSPT



Heating resistor

PS Automation GmbH

Philipp-Krämer-Ring 13 • D-67098 Bad Dürkheim
+49 6322 94980-0 • info@ps-automation.com
www.ps-automation.com

Engineered and Made in Germany

