

Linear actuators PS-AMS PSL 2 kN - 25 kN with Power Fail-Safe Device PSCP

Most industrial facilities are not equipped with secondary electrical circuits and emergency power supplies. Blackouts as they frequently occurred in recent years do not only mean a loss of productivity but also a loss of control. If the production in the process industry and in some processes of discrete manufacturing stops without control, that may spoil the complete production batch. Failures in cooling or heating supplies may disrupt all work flows in utility systems. And they may evoke dangers for employees or environment.

Mode of functioning

The capacitor-based energy storage is powerful and maintenance free. As soon as the actuator's electronics recognize a main power failure, it instantly switches its own PSCP energy pack and the actuator moves towards the valve's preset safety position. This happens safely with preset thrust or torque and speed. A potential-free relay contact is available that delivers the information about emergency positioning to the control room. The PSCP is designed for above 500.000 load cycles.

Benefits

- Maintenance-free operation without the familiar battery „memory effect“
- High durability based on long-term experience in various applications
- High number of life cycles and load capability due to a low internal resistance, full force is available at all times
- Very good tolerance to low temperature
- Recharging within a few minutes without losing capacity, therefore the actuator is quickly made ready for a new emergency cycle

PS-AMS PSL is compact and modular

The PS-AMS PSL linear actuators from PS Automation are available for forces from 1 kN to 25 kN. They are mature and proven, robust and completely maintenance free.

PS-AMS PSL is installed fast and is programmable due to the local control with display, alternatively via the USB-interface.

The automated one-key commissioning is standard.



Dimension and technical Data

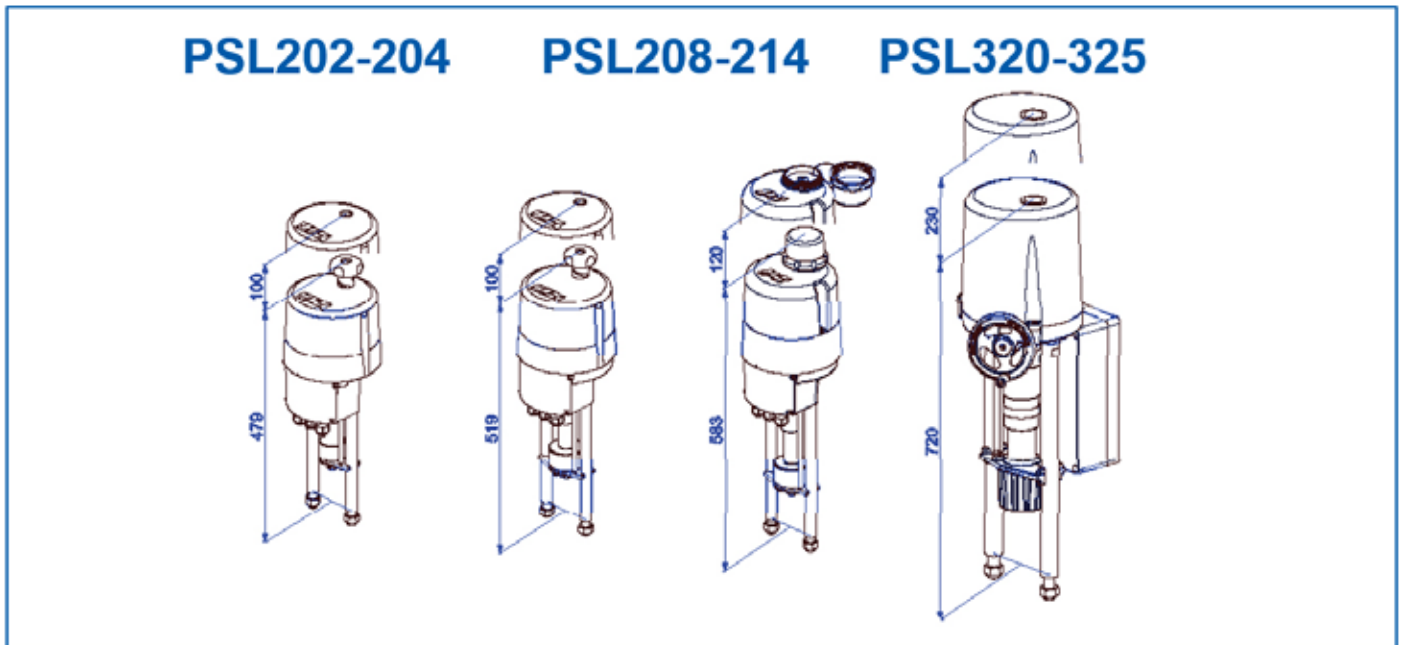

Intelligent linear actuators		PSL202 AMS11	PSL204 AMS11 AMS12	PSL208 AMS11	PSL210 AMS11 AMS12	PSL214 AMS12	PSL320 PSL325 AMS13	
Thrust	kN	2,3	4,5	8	10	14	25	
	Lb _f	520	1010	1800	2250	3150	5600	
Stroke s	mm	50	50	50 opt. 65	50 opt. 65	50 opt. 65	60 100 (24V)	
	mm	100	100	100	100	100	155	
Manual override		Handwheel knob					Handwheel	
Velocity	mm /s	0,45 - 0,9	0,45 - 0,9 2,25 - 4,5	0,3 - 0,7	0,2 - 0,35 0,85 - 1,7	0,65 - 1,3	0,2 - 0,4	
	Motor voltages	24 V AC+DC / 115 V / 230 V / 50-60 Hz						
Motor protection	Electronic motor current monitoring with safety cut-off							
Duty cycle as per IEC 60034-1,8	S2 30min, S4 1200 c/h - 50% duty cycle							
Permitted ambient temperature	-20 to +55°C							
Control options (standard)	Analogue signal, split range, 24 V binary							
Input and Output signals	0 (4) - 20 mA, 0 (2) - 10 V							
Mounting position	Any position, except cover pointing downwards							
Enclosure acc. to EN 60529 (PSCP)	IP65		IP67			IP65		
Gear case material	High quality aluminium die casting							
Cover material	Polycarbonat			Cast aluminium				

PS Automation GmbH

Philipp-Krämer-Ring 13
D-67098 Bad Dürkheim

Tel.: +49 (0) 6322 94980 – 0
E-Mail: info@ps-automation.com
www.ps-automation.com

