

PSF-Q-M-EX AUTOMATION

we care for actuation

Electrical 90° explosion-proof quarter-turn actuator with manual override

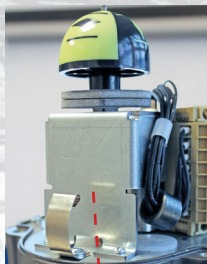

Contactless, non-wearing travel detection with **Hall sensor** for exact positioning



Robust industrial design with **metal cover, enclosure IP67**

Brushless DC motor (BLDC) Controller with integrated positioner function

Explosion-proof terminals

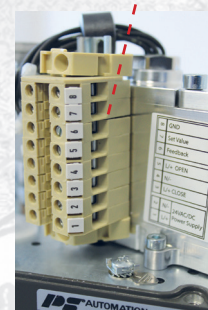

Inspection glass to show LED signals in hazardous environment

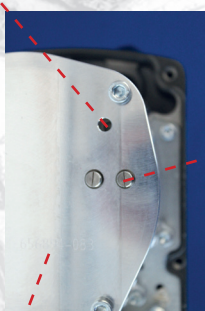

Manual operation of the actuator is also possible in hazardous environment

Manual operation with push buttons. Parameter setting via DIP switches



Pressure-tight casing for applications in Zone 1, 2, 21, 22

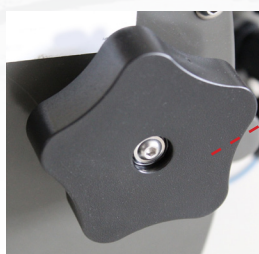

Manual operation with handwheel

Technical Data

		PSF-Q-M50-EX	PSF-Q-M80-EX
Device category		II 2G II 2DG	
EU Type Examination Certificate		TPS 22 ATEX 110398 0002 X	
ATEX directive gases		Ex h db eb IIC T6/T4 Gb	
ATEX directive dusts		Ex h tb IIIC T80°C/T100°C Db	
Torque	Nm	50	80
Operating Time / 90°		16 / 20 / 30 s (adjustable)	16 / 20 / 30 s (adjustable)
Flange (ISO 5211)		F05 / F07	
Power supply	V	24 VAC/DC, 100 - 240 VAC	
Weight approx.	kg	7.2	
Frequency	Hz	50 - 60	
Nominal / Maximum Current	A	0.1 / 0.8	0.15 / 1.3
Power Consumption	W	15 (100-240 VAC) / 15 (24 VAC) / 12 (24 DC)	23 (100-240 VAC) / 23 (24 VAC) / 18 (24 DC)
Duty cycle as per IEC 60034-1,8		S2 30 min / S4 50% ED - 1200c/h	
Permitted ambient temperature		-10 to +60°C	
Motor Protection		Electronic motor current monitoring with safety cut-off	
Overvoltage Category		II	
Binary control		24 - 230 VAC & 24 VDC for ON/OFF service	
Set value and feedback		0-20 mA, 4-20 mA, 0-10 V, 2-10 V selectable	
Valve Positioner Function		Integrated, deadband 0.6% of full signal range, shut-off minimum	
Automatic commissioning		Recognizing the end position(s) and autoscaling set and feedback values	
Internal Fault Monitoring		Torque, set value, temperature, power supply	
Cable Glands		2 pcs. ISO M20 x 1.5 and 1 pcs. ISO M16 x 1.5	

Dimensions

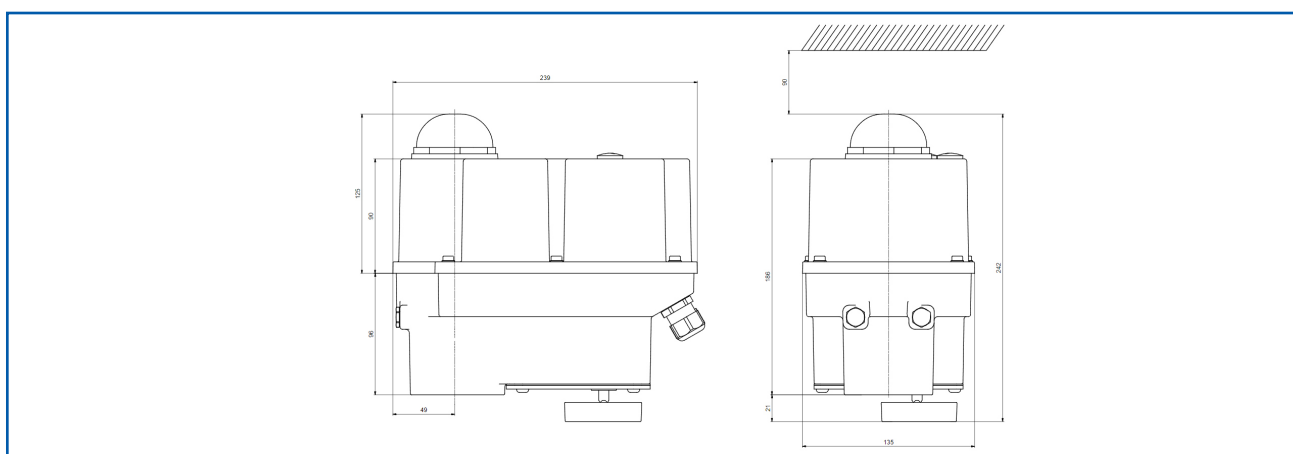

PS Automation GmbH

Philipp-Kraemer-Ring 13 • D-67098 Bad Dürkheim
 +49 (0) 6322-94980-0 • info@ps-automation.com
 www.ps-automation.com

Engineered and Made in Germany

