

Operating Instructions

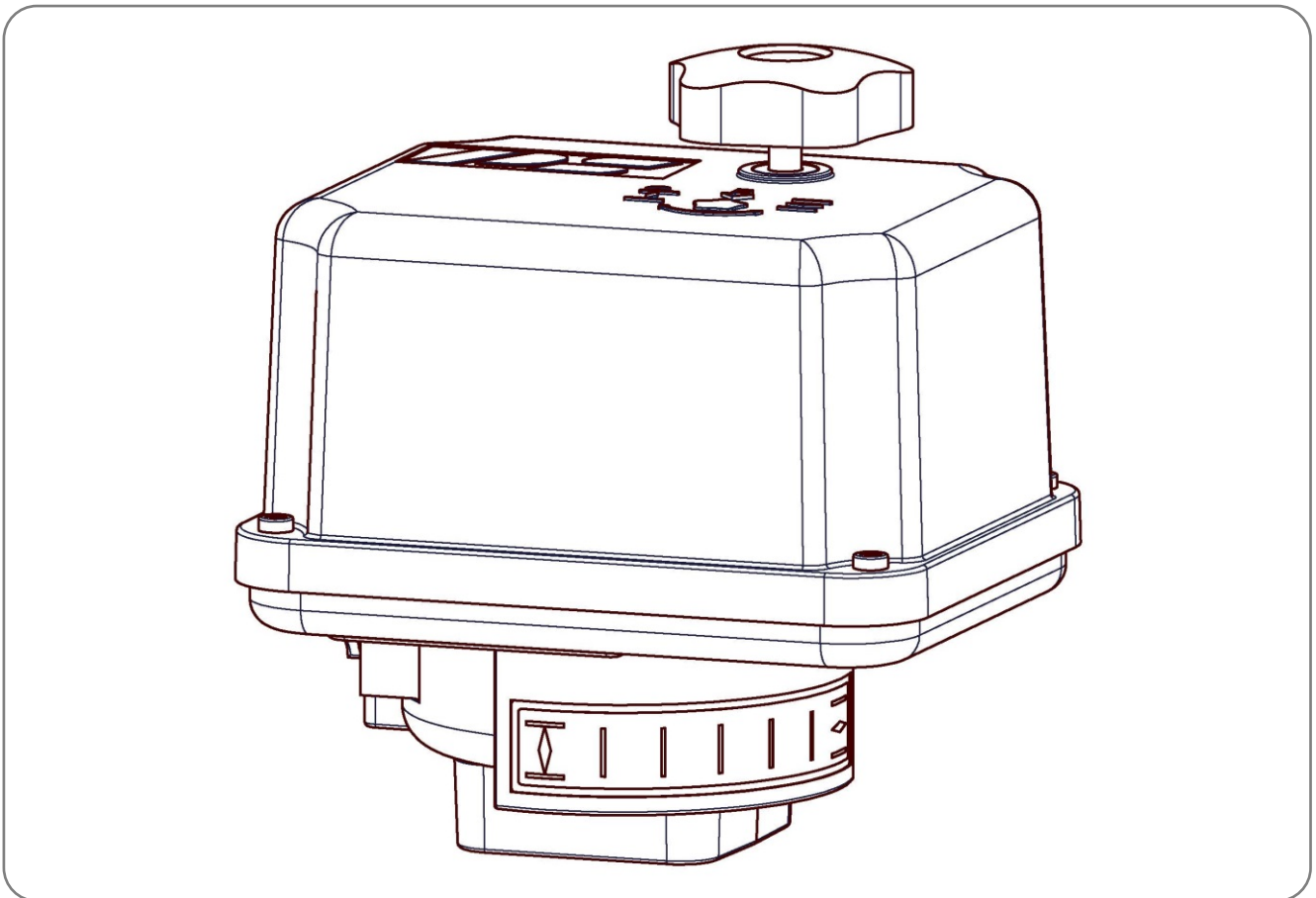

Contents

- Technical data 2
- Type key 2
- 1. Symbols and safety 3
- 2. Usage as per specification..... 4
- 3. Storage 4
- 4. Operating conditions..... 4
- 4.1 Installation position 5
- 5. Manual operation 6
- 6. Valve mounting 6
- 7. Setting of the mechanical stop 7
- 8. Setting of the position switches/ limit switches 7
- 8.1 Setting of the internal limit switches 8
- 8.2 Setting of the additional position switches..... 8
- 9. Electric supply 9
- 9.1 Wiring diagram..... 9
- 10. Commissioning 10
- 11. Service/ Maintenance 10
- 11.1 Cleaning..... 10
- 11.2 Spare Parts 10
- 12. Decommissioning and disposal 10
- 13. Appendix 11
- 13.1 Accessories..... 11
- 13.2 CE Declaration of Conformity 12
- 13.3 CA Declaration of Conformity 13

Technical data

The technical data of the actuators is specified on the name plate and the data sheets for further information.

Type key

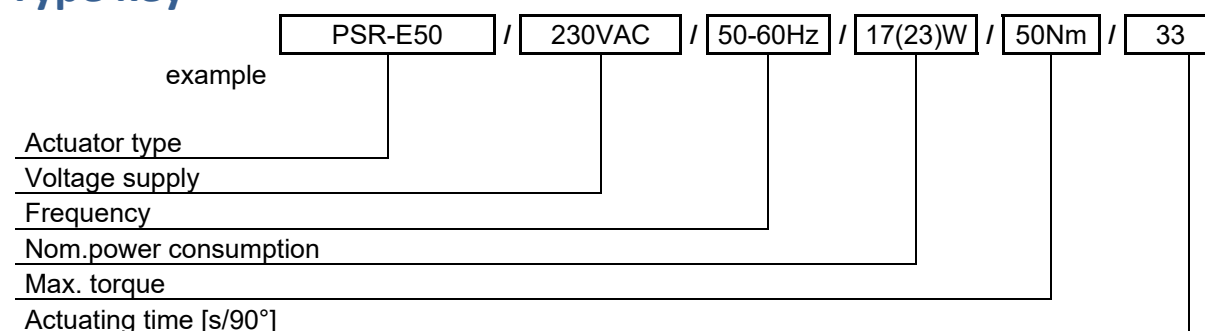

1. Symbols and safety

Danger signs

The following danger signs are used in this operating manual:



Caution! There is a general risk of damage related to health and/or properties.



Danger! Electrical voltages are present that may lead to death. Avoid personal or material damages by observing applicable regulations and safety standards!

Other notes

- The motor surface temperature may rise when maintaining, inspecting and repairing the actuator immediately after the operation. There is a danger of burning the skin!
- Always consult the relevant operating instructions when mounting PS-S accessories or operating the actuator with PS accessories.
- Connections for signal in- and output are double isolated from circuits that can be under dangerous voltage.

General dangers of non-compliance with safety regulations

PSR-E actuators are built at state-of the art technology and are safe to operate. Despite of this, the actuators may be hazardous if operated by personnel that has not been sufficiently trained or at least instructed, and if the actuators are handled improperly, or not used as per specification.

This may

- cause danger to life and limb of the user or a third party,
- damage the actuator and other property belonging to the owner,
- reduce safety and function of the actuator.

To prevent such problems, please ensure that these operating instructions and the safety regulations in particular have been read and understood by all personnel involved in the installation, commissioning, operation, maintenance and repair of the actuators.

Basic safety notes

- The actuators may only be operated by skilled and authorized operating personnel.
- Make sure to follow all security advices mentioned in this manual, any national rules for accident prevention, as well as the owner's instructions for work, operation and safety.
- The isolating procedures specified in these Operating Instructions must be followed for all work pertaining to the installation, commissioning, operation, change of operating conditions and modes, maintenance, inspection, repair and installation of accessories
- Before opening the actuator cover, ensure that mains supply is isolated and prevented from unintended re-connection.
- Areas that can be under voltage have to be isolated before working on them.
- Ensure that the actuators are always operated in faultless condition. Any damage or faults, and changes in the operational characteristics that may affect safety, must be reported at once.

2. Usage as per specification

- PSR-E quarter turn actuators are exclusively designed to be used as electric valve actuators. They are meant to be mounted on valves in order to run their motors.
- Any other use is considered to be non-compliant and the manufacturer cannot be held liable for any damage resulting from it.
- The actuators can only be used within the limits laid out in the data sheets, catalogues and other documents. Otherwise, the manufacturer cannot be held liable for any resulting damage.
- Usage as per specification includes the observance of the operating, service and maintenance conditions laid down by the manufacturer.
- Not to be regarded as usage as per specification are mounting and adjusting the actuator as well as servicing. Special precautions have to be taken while doing this!
- The actuators may only be used, serviced and repaired by personnel that is familiar with them and informed about potential hazards. The specific regulations for the prevention of accidents have to be observed.
- Damages caused by unauthorized modifications carried out on the actuators are excluded from the manufacturer's liability.
- Supply voltage may only be switched on after the proper closure of the main cover or terminal box.
- Electrical wiring is done to a terminal block under the actuator cover.

3. Storage

For appropriate storage, the following instructions have to be met:

- Only store the actuators in ventilated, dry rooms.
- Store the actuators on shelves, wooden boards, etc., to protect them from floor moisture.
- Cover the actuators with plastic foil to protect them from dust and dirt.
- Protect the actuators against mechanical damage.

4. Operating conditions

- Actuators with synchronous motors can fluctuate by up to +/-20% in the actuating force with +/-10% voltage fluctuation.
- Standard actuators may be operated at ambient temperatures from -25°C to +70°C.
- Operating modes correspond to IEC 60034-1, 8: S2 for short cycle 20 min. S3/S4 control operation 1200 c/h – 25% ED at 25°C.
- For protection against moisture and dust, enclosure rating is IP65 (optionally IP67) according to EN 60529. To ensure this enclosure, the cover must be fitted correctly and the screws tightened cross wise after opening. The hand wheel must be fitted to the hand wheel shaft. The cable glands must be suitable for the wiring and correctly fitted to the actuator. To maintain the degree of protection IP65 (resp. IP67), cable glands M20x1,5 must be used which are suitable for the cable diameter.
- Space needed to remove the cover: 100 mm above the actuator

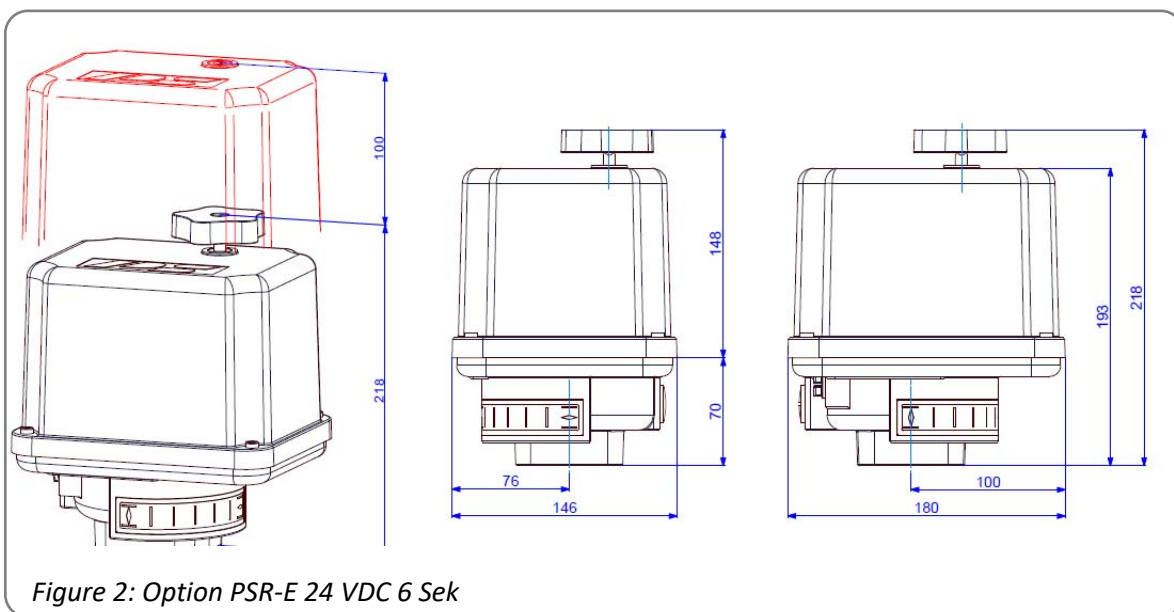
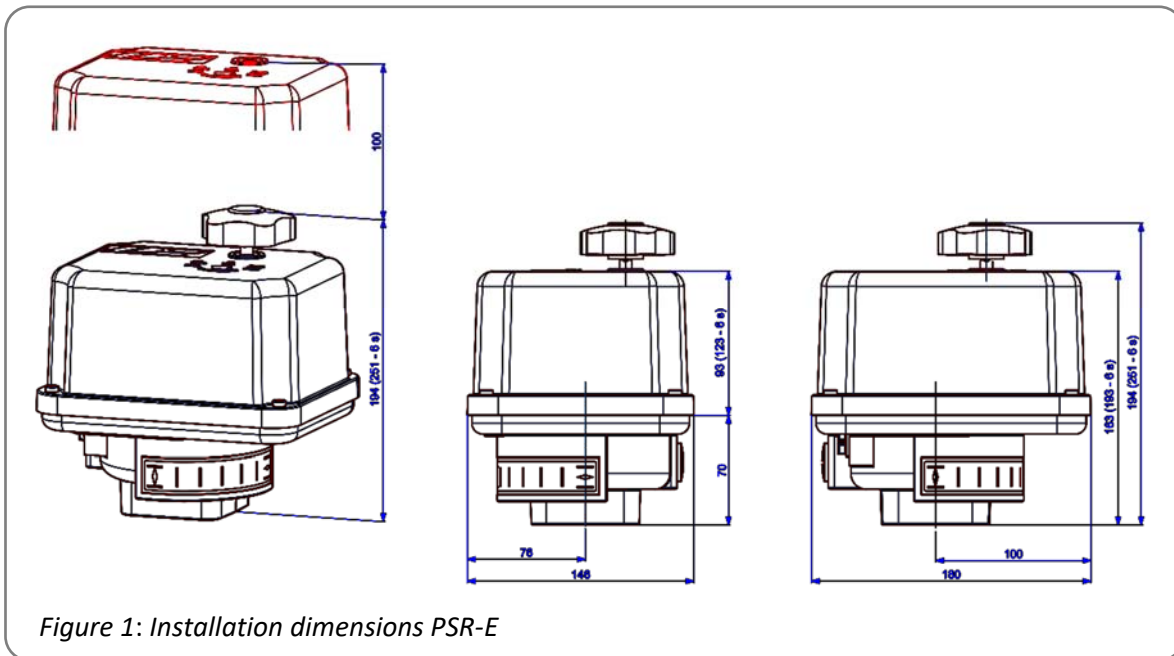

Outdoor usage:

When using actuators in environments with high temperature fluctuations or high humidity, we suggest a heating resistor to be fitted to prevent the build-up of condensation within the enclosure.

4.1 Installation position

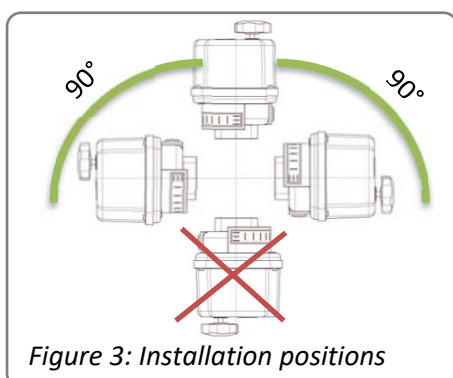

The actuator can be installed vertically or horizontally or any position in between. The actuator must not be installed with the cover pointing downwards.

The electric quarter-turn actuators Series PSR-E are designed to operate valves with 90° angular motion using the ON/ OFF mode. The PSR-E actuators are provided with a mechanical interface according to ISO 5211 for valve mounting. The motor torque is transmitted via spur gear, indirectly transmitted onto a double square drive bush. This drive bush is used as a connecting piece between actuator and valve shaft.

The 90° rotation is adjustable mechanically +/- 5° in one end position. Two adjustable switches limit the rotation in both directions, interrupting the motor current when reaching the adjusted end position.

The hand wheel allows manual operation in case of power failure and during adjustment (See pt. 6).

5. Manual operation

The hand wheel allows manual operation in case of power failure or during adjustments (Mounting or positioning the valve). For manual operation, the hand wheel has to be pushed down against a spring.

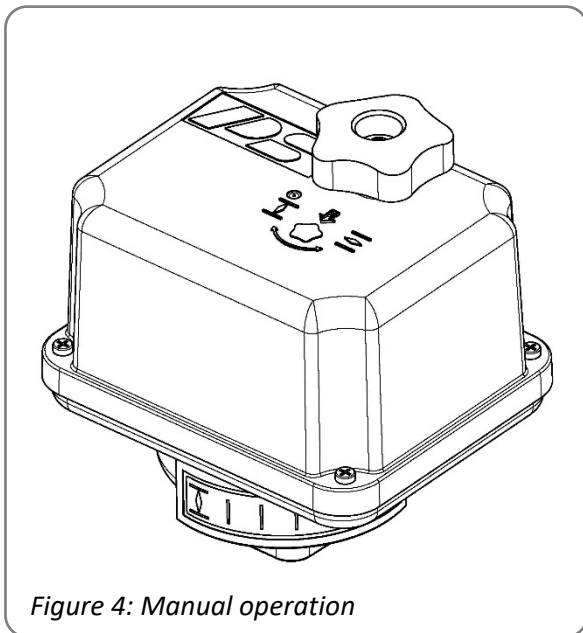

Figure 4: Manual operation

Do not exceed the adjusted electrical stroke limits by using the hand wheel.

The mechanical stop must be set accordingly to protect the valve.



If you don't observe this warning, the electrical feedback setting will change!

6. Valve mounting

The PSR-E actuators are designed with a mechanical interface according to ISO 5211 for valve mounting. The gear contains an exchangeable drive bush to connect the actuator to the valve shaft.

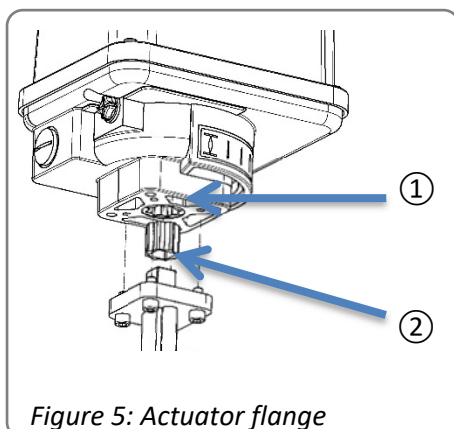

Figure 5: Actuator flange

- Check if the actuator flange suits the valve flange
- Use standard adapters to adapt to the valve shaft
- Clean the surface of the connection components, lubricate valve shaft slightly
- Position the actuator on the valve
- Tighten the screws in a diagonal sequence according to the required torque

① Actuator flange

② Adapter for valve spindle

7. Setting of the mechanical stop

There is one adjustable screw available for setting the mechanical limit of the 90° angular stroke.



When setting the mechanical end positions, only the hand wheel may be used. Do not operate the actuator electrically!

- Remove the protection cap (Figure 6, Pos. 2) from the stop screw.
- Back off the stop screw counter-clockwise approx. 5 turns.
- Move the actuator to the closed position by turning the hand wheel clockwise.
- Turn stop screw for closed position (Figure 6, Pos. 1) finger tight, then a half turn back.
- Screw on the protection cap onto the stop screw.

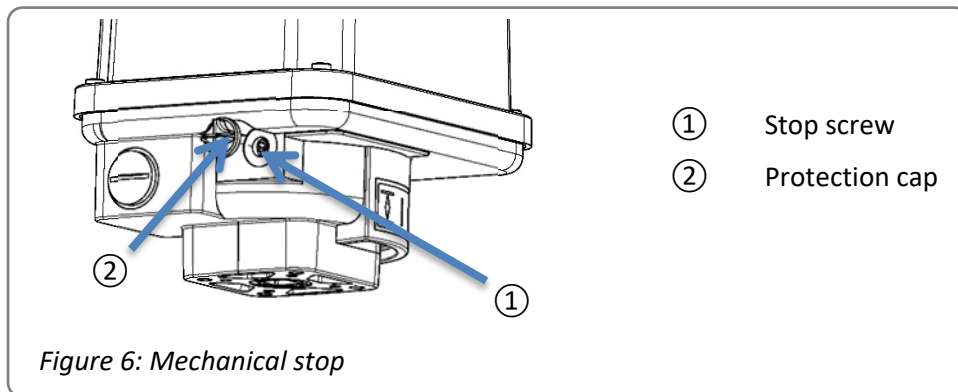

8. Setting of the position switches/ limit switches

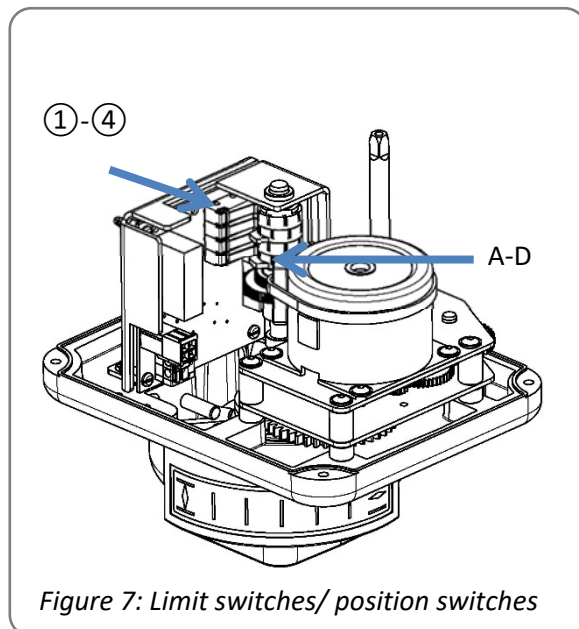

The limit switches are pre-adjusted in the factory.

These standard limit switches serve to switch off the motor when the end positions are reached.

Additional position switches are free of voltage and serve to indicate the valve position.

- ① Position switch OPEN
- ② Position switch CLOSE
- ③ Limit switch OPEN
- ④ Limit switch CLOSE

A-D Switching cams

8.1 Setting of the internal limit switches



Ensure that the mains supply is secured against accidental switching-on!

- The limit switches are pre-adjusted in the factory. An additional adjustment of the two lower switching cams is normally not necessary. If you wish to adjust the limit switches yourself, please follow these instructions:
- Run the actuator by using the hand wheel in direction to the closed position until the required position is reached.
- Turn the cam of the CLOSE limit switch (Figure 8; Pos. D) with a suitable screw driver (4 mm blade width) clockwise until you hear the micro switch click.
- Run the actuator by using the hand wheel in direction to the open position until the required position is reached.
- Turn the cam of the OPEN limit switch (Figure 8; Pos. C) with a suitable screw driver (4 mm blade width) counter-clockwise until the micro switch is heard to click.
- Check the switching position and repeat the adjustment if necessary.

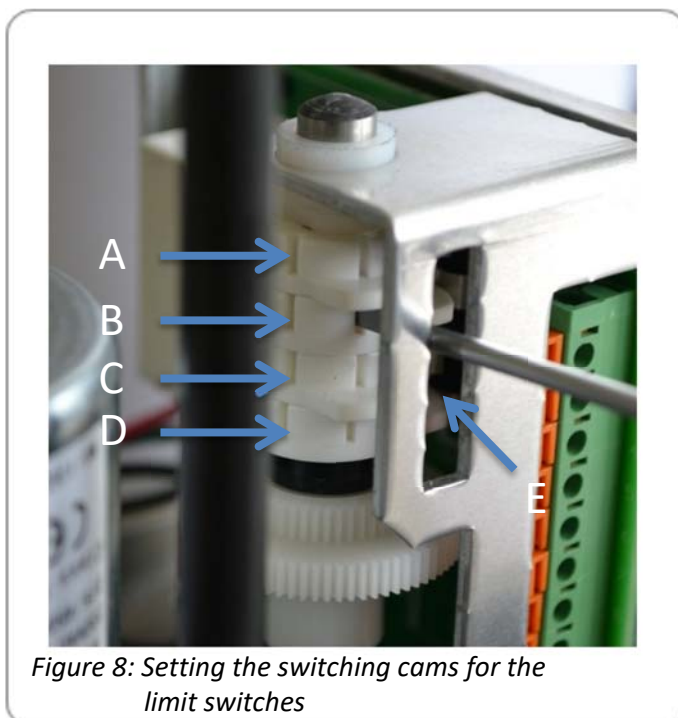

Figure 8: Setting the switching cams for the limit switches

- A Switching cam for ① position switch OPEN/ Feedback signal
- B Switching cam for ② position switch CLOSE/ Feedback signal
- C Switching cam for ③ limit switch OPEN/ Motor cut-off
- D Switching cam for ④ limit switch CLOSE/ Motor cut-off
- E Supporting bridge for screwdriver

NOTE:

Use the bridge (Figure 8; Pos. E) as support for the screw driver when adjusting the cams.

8.2 Setting of the additional position switches

- Run the actuator by using the hand wheel in direction to the CLOSE position until the required position is reached.
- Turn the cam of the the CLOSE limit switch (Figure 8; Pos. B) with a suitable screw driver (4 mm blade width) clockwise until the micro switch is heard to click.
- Run the actuator by using the hand wheel in direction to the OPEN position until the required position is reached.
- Turn the cam of the OPEN limit switch (Figure 8; Pos. A) with a suitable screw driver (4 mm blade width) counter-clockwise until the micro switch is heard to click.
- Check the switching position and repeat the adjustment if necessary.

9. Electric supply



Switch mains off before starting to work!

Connect acc. to wiring diagram on the main frame.

Mains connection cables must be dimensioned suitably to accept the maximum current requirement of the actuator and correspond to IEC 227 and IEC 245.

The yellow-green coloured cables may be used only for connecting to earth.

When you insert cables through the cable connector, ensure that the maximum bending radius for the cables is observed.

PSR-E electric actuators do not have an internal electrical power switch. A switch or power mains switch has to be provided therefore in plant installation. This should be positioned close to the device and easily accessible to the user; it shall be labelled as the mains isolator switch for the actuator.

Plant installation must also provide power surge trips or fuses corresponding to standard IEC 364-4-41/ DIN VDE 0100-410 with protection class 1 for the actuator connections.

9.1 Wiring diagram

Figure 9 shows the standard electrical connections. However, the wiring diagram inside the actuator hood is valid for the specific actuator. For any optional extras see the individual wiring diagram in the related service instructions.

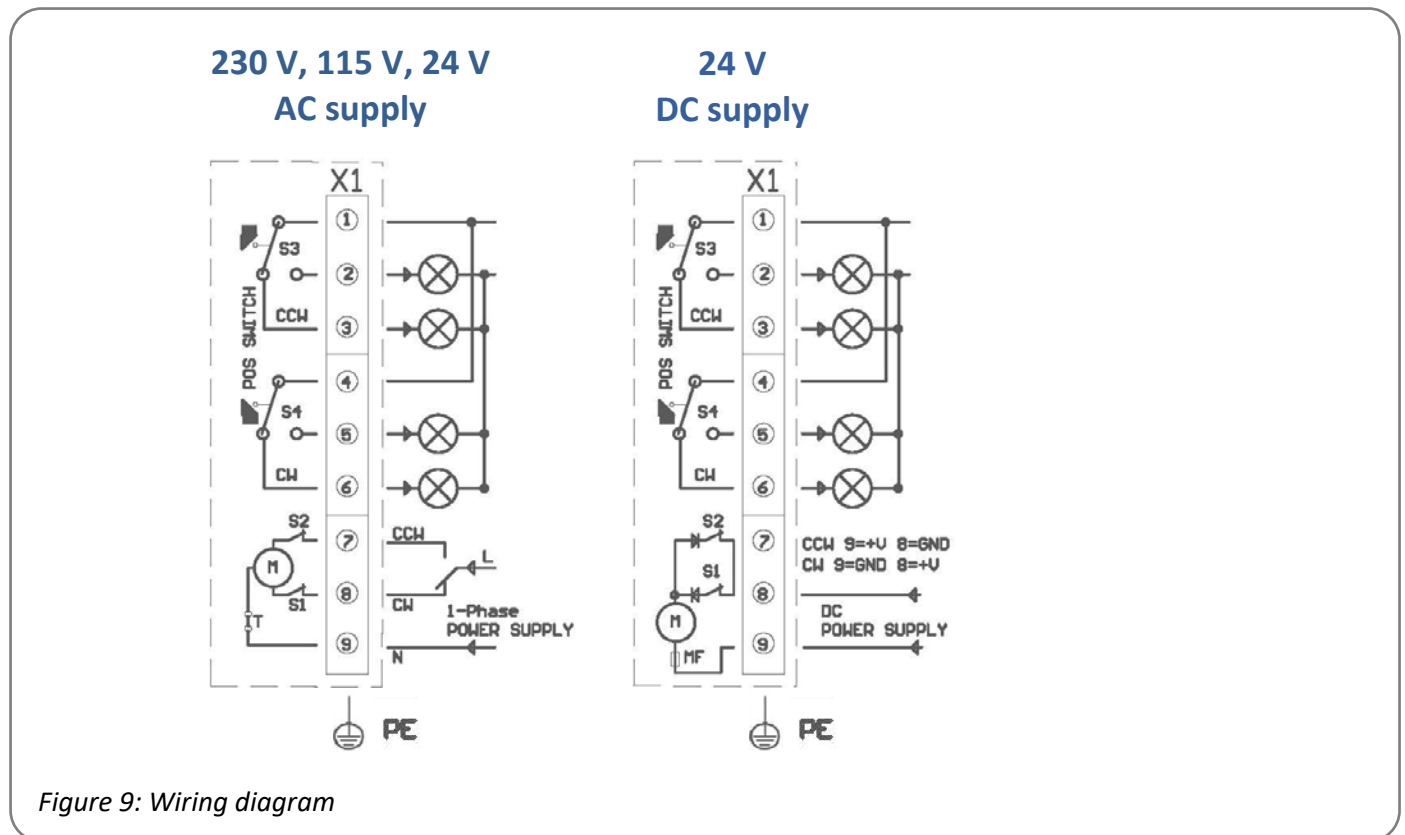

Two adjustable limit switches are installed to limit the stroke of the actuator, and cut-off the motor current in the relative direction.



PE Earth connection on housing plate has to be connected!



Ensure that all connecting cables are stripped to the correct length so that they are protected against electric shock.

10. Commissioning

- Drive the actuator into an intermediate stroke position using the hand wheel.
- Switch the setting signal briefly between OPEN and CLOSE and ensure that the actuator operates in the correct direction. If necessary, reverse the setting signal for OPEN / CLOSE.
- Drive the actuator, in both directions, using the setting signal until the limit switch cuts-off. Ensure that the limit switch position is correct. If necessary re-adjust the limit switches.



The electrical connection and commissioning with mains voltage applied may only be carried out by trained specialist personnel!

Do not touch any connection lines during commissioning!

11. Service/ Maintenance

The actuators are maintenance-free if used under the operating conditions as stated in the data sheet. The gearboxes are lubricated for lifetime and do not require further lubrication.

11.1 Cleaning

The actuators should be cleaned dryly.

11.2 Spare Parts

Defective actuators should be returned to our plant in Bad Dürkheim, Germany, or to our representatives, to be checked for damages and their possible causes.

12. Decommissioning and disposal

- Disconnect the mains supply and ensure that it is secured against an accidental switching-on.
- Open the cover.
- Remove external electrical connections.
- Take off the actuator from the valve.

Disposal

For its disposal, the product should be treated as waste containing electrical and electronic equipment and should not be disposed of as household waste.



In accordance with 2012/19/EU on waste electrical and electronic equipment (WEEE), the devices described here may not be disposed of via municipal waste disposal companies.

If you are unable or unwilling to arrange for the equipment to be disposed of by a specialist company, you may return the equipment to the manufacturer, who will then ensure that the equipment is disposed of properly for a flat fee.

13. Appendix

13.1 Accessories

Various options are available in order to adapt the actuators to the various service conditions. A list of accessories for each actuator type is shown on the actuator data sheet.

Accessories / Options		230 VAC 1~	115 VAC 1~	24 VAC	24 VDC
Heating	HR	1000-424		1000-433	
Potentiometer	PD	1000-535			
Position Transmitter	PSPT	PSPT02: 2-wire technology; PSPT03:3-wire technology			
Increased Enclosure	IP	Increase of enclosure to IP67			

13.2 CE Declaration of Conformity

Declaration of Incorporation of Part Completed Machinery and EC Declaration of Conformity in compliance with the Directives on EMC and Low Voltage

We,

PS Automation GmbH
Philipp-Krämer-Ring 13
D-67098 Bad Dürkheim

Declare under our sole responsibility that we manufacture electric actuator series

**PSR-E...; PSQx03...; PSQ-E...; PSQ-AMS...; PSL-Mod.4...;
PSL-AMS...; PSF...; PSF-M...; PSF-Q...; PSF-Q-M...**

according the requirements of the

EC Directive 2006/42/EC

as part completed machinery. These actuators are designed to be installed on industrial valves.
It is prohibited to take the actuator into service until it has been ensured that the complete machine conforms
the applicable machinery directives.

The technical documentation described in Annex VII, part B has been prepared.

The above actuators further comply with the requirements of the following directives.

2014/30/EU	Electromagnetic Compatibility (EMC)
2014/35/EU	Low Voltage (LVD)
2011/65/EU + 2015/863/EU	Restriction of Hazardous Substances (RoHS)

furthermore, the following harmonised standards have been applied:

EN 61000-6-2: 2005	Electromagnetic compatibility (EMC), Generic standards- Immunity for industrial environments
EN 61000-6-3: 2007	Electromagnetic compatibility (EMC), Generic standards- Emission standard for residential, commercial and light-industrial environments
EN 61010-1: 2020	Safety Requirements for Electrical Equipment for Measurement, Control and Laboratory use

Bad Dürkheim, 2022



Christian Schmidhuber
(General Manager)

CAUTION!

To ensure compliance of these actuators with the above directives, it is the responsibility of the specifier, purchaser, installer and user to observe the relevant specifications and limitations when taking the product into service. Details are available on request, and are mentioned in the Installation and Maintenance Instructions.

13.3 CA Declaration of Conformity

Declaration of Incorporation of Part Completed Machinery and CA Declaration of Conformity in compliance with the Legislation on EMC and Low Voltage

We,

**PS Automation GmbH
Philipp-Krämer-Ring 13
D-67098 Bad Dürkheim**

Declare under our sole responsibility that we manufacture electric actuator series

PSR-E...; PSQx03...; PSQ-E...; PSQ-AMS...; PSL-Mod.4...; PSL-AMS...; PSF...; PSF-M...

according to the requirements of the

2008 No. 1597

Supply of machinery (safety) regulations

as part completed machinery. These actuators are designed to be installed on industrial valves.

It is prohibited to take the actuator into service until it has been ensured that the complete machine conforms to the applicable machinery legislation.

The technical documentation described in Annex VII, part B has been prepared.

The above actuators further comply with the requirements of the following legislations:

**UK SI 2016 No. 1091 and
Amendments**

The Electromagnetic Compatibility Regulations 2016

**UK SI 2016 No. 1101 and
Amendments**

The Electrical Equipment (Safety) Regulations 2016

**UK SI 2012 No. 3032 and
Amendments**

**The Restriction of the Use of Certain Hazardous Substances in
Electrical and Electronic Equipment Regulations 2012**

the provisions of the legislations and their compliance are given by the following named standard(s), which have been applied:

EN 61000-6-2: 2005

Electromagnetic compatibility (EMC), Generic standards-
Immunity for industrial environments

EN 61000-6-3: 2007

Electromagnetic compatibility (EMC), Generic standards-
Emission standard for residential, commercial
and light-industrial environments

EN 61010-1: 2020

Safety Requirements for Electrical Equipment for
Measurement, Control and Laboratory use

Bad Dürkheim, 2021



Christian Schmidhuber
(General Manager)

CAUTION!

To ensure compliance of these actuators with the above directives, it is the responsibility of the specifier, purchaser, installer and user to observe the relevant specifications and limitations when taking the product into service. Details are available on request, and are mentioned in the Installation and Maintenance Instructions.

Our representatives:

Italy

PS Automazione S.r.l.
Via Pennella, 94
I-38057 Pergine Valsugana (TN)
Tel.: <+39> 04 61-53 43 67
Fax: <+39> 04 61-50 48 62
E-mail: info@ps-automazione.it

India

PS Automation India Pvt. Ltd.
Srv. No. 25/1, Narhe Industrial Area,
A.P. Narhegaon, Tal. Haveli, Dist.
IND-411041 Pune
Tel.: <+ 91> 20 25 47 39 66
Fax : <+ 91> 20 25 47 39 66
E-mail : sales@ps-automation.in
www.ps-automation.in

To find out more about all our sales partners and subsidiaries please scan the QR code below or visit our website:

<https://www.ps-automation.com/locations/?lang=en>



PS Automation GmbH

Philipp-Krämer-Ring 13
D-67098 Bad Dürkheim

Phone: +49 (0) 6322 94980-0
E-mail: info@ps-automation.com
www.ps-automation.com

