

Operating Instructions

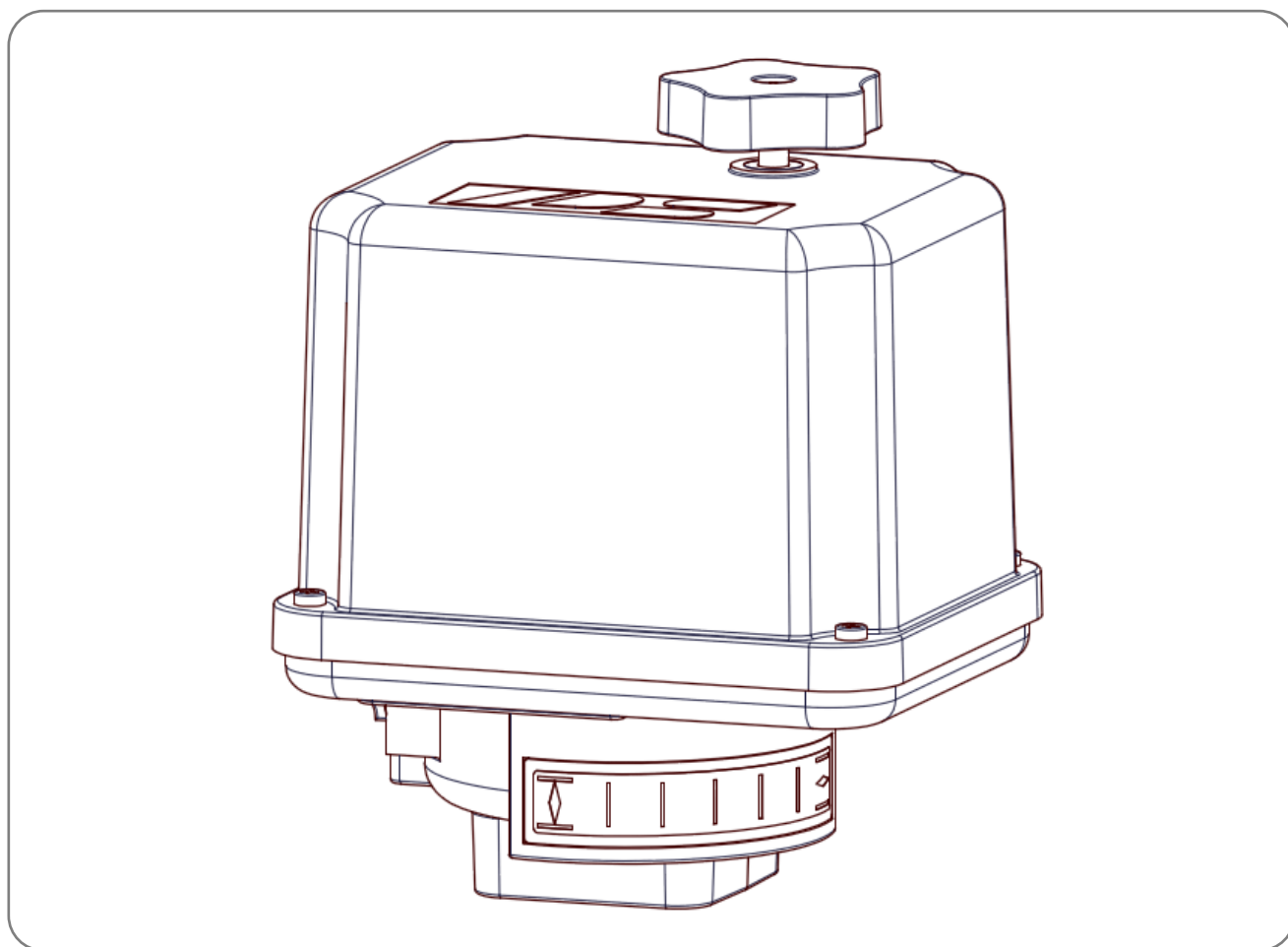

Content

| | |
|--|----|
| 1. Safety | 3 |
| 2. Usage as per specification..... | 4 |
| 3. Storage | 4 |
| 4. Principle of operation | 4 |
| 5. Operating conditions and installation position..... | 4 |
| 6. Manual operation | 5 |
| 7. Electric supply | 6 |
| 7.1 Wiring diagram..... | 6 |
| 7.2 Thermal switch as potential free contact | 7 |
| 8. Valve mounting | 8 |
| 9. Setting the mechanical stop..... | 8 |
| 10. Adjustment of limit switches | 9 |
| 11. Commissioning..... | 9 |
| 12. Maintenance | 10 |
| 12.1 Cleaning..... | 10 |
| 12.2 Spare parts | 10 |
| 13. Decommissioning and disposal | 10 |
| 14. Appendix | 11 |
| 14.1 Technical data and accessories..... | 11 |
| 14.2 CE Declaration of Conformity | 12 |
| 14.3 CA Declaration of Conformity | 13 |

1. Safety

Dangers of non-compliance with safety regulations

PSR-E-C actuators are built to state-of-the-art technology and are safe to operate. Despite this, the actuators may be hazardous if operated by personnel that has not been sufficiently trained or at least instructed, and if the actuators are handled improperly, or not used as per specification.

This may

- cause danger to life and limb of the user or a third party,
- damage the actuator and other property belonging to the owner,
- reduce safety and function of the actuator.

To prevent such problems, please ensure that these operating instructions and the chapter on "Safety" in particular have been read and understood by all personnel involved in the installation, commissioning, operation, maintenance and repair of the actuators.

Basic safety notes

- The actuators may only be operated by skilled and authorized operating personnel.
- Make sure to follow all security advices mentioned in this manual, any national rules for accident prevention, as well as the owner's instructions for work, operation and safety.
- The isolating procedures specified in these operating instructions must be followed for all work pertaining to the installation, commissioning, operation, change of operating conditions and modes, maintenance, inspection, repair and installation of accessories.
- Before opening the actuator cover, ensure that mains supply is isolated and prevented from unintended re-connection.
- Areas that can be under voltage have to be isolated before working on them.
- Ensure that the actuators are always operated in faultless condition. Any damage or faults, and changes in the operational characteristics that may affect safety, must be reported at once.

Danger signs

The following warning symbols are used in this manual:



Caution! There is a general risk of damage to health and/or properties.



Danger! Electrical voltages may be present that are dangerous to life!

Other notes

- The motor surface may have elevated temperature when servicing, inspecting or repairing it immediately after operation. Danger of burning the skin!
- Always observe the relevant operating instructions when fitting PS accessories or operating the actuator with PS accessories.
- Connections for signal in- and output are double isolated from circuits that can be under dangerous voltage.

2. Usage as per specification

- The PSR-E-C quarter turn actuators are exclusively designed as electric valve actuators. They are meant to be mounted on valves for motor-operation.
- Any other use is considered to be not in accordance with standard specification, and the manufacturer cannot be held liable for any damage resulting from it.
- The actuators may not be used outside the limits laid out in data sheets, catalogs and order documentation. Otherwise the manufacturer cannot be held liable for any resulting damage.
- Usage as per specification includes the observance of the operating, service and maintenance conditions laid down by the manufacturer.
- Not to be regarded as usage as per specification are mounting and adjustment of the actuator, and servicing. Special precautions have to be taken while doing this!
- The actuators may only be used, serviced and repaired by personnel that are familiar with them and informed about potential hazards. The specific regulations for the prevention of accidents have to be observed.
- Damages caused by unauthorized modifications carried out on the actuators are excluded from the manufacturer's liability.
- Supply voltage may be switched on only after properly closing the main cover or terminal box.

3. Storage

Proper storage means:

- Only store the actuators in ventilated, dry rooms.
- Store the actuators on shelves, wooden boards, etc., to protect them from floor moisture.
- Cover the actuators with plastic foil to protect them from dust and dirt.
- Protect the actuators against mechanical damage.

4. Principle of operation

The electric quarter-turn actuators series PSR-E-C are designed to operate valves with 90° angular motion. The PSR-E-C actuators are provided with a mechanical interface according to ISO 5211 for valve mounting. The motor torque is transmitted via spur gear, indirectly transmitted onto a coupling with double square. This is used as connecting piece between actuator and valve shaft.

The 90° rotation is adjustable mechanically +/- 5° in one end position. Two adjustable switches limit the rotation in both directions, interrupting the motor current when reaching the adjusted end position.

The handwheel allows manual operation in case of power failure and during adjustment. Depending on the operating time of the actuator, the handwheel is either permanently engaged, or it has to be pushed down against a spring for manual operation. A sticker on the actuator cover indicates the relevant mode for manual operation. At motor operation, the handwheel serves as running indicator.

Electrical wiring is done to a terminal block under the actuator cover.

5. Operating conditions and installation position

- Actuators with synchronous motors can fluctuate by up to +/-20% in the actuating force with +/-10% voltage fluctuation.
- Standard actuators may be operated at ambient temperatures from -20°C to +80°C
- Ambient temperature range for modulating service is -25°C to +70°C (S2) resp. -20°C to +60°C (S4).
- Operating modes correspond to IEC 60034-1, 8: S2 for short cycle and S4 for control service (see data sheet for specific values for each actuator size).
- For protection against moisture and dust, enclosure rating is IP65 according to EN 60529. To ensure this enclosure, the cover must be fitted correctly and the screws tightened cross wise after opening. The handwheel must be fitted to the handwheel shaft. The cable glands must be suitable for the wiring and correctly fitted to the actuator.
- When installing the actuators, leave enough space to allow cover removal (Fig.1).

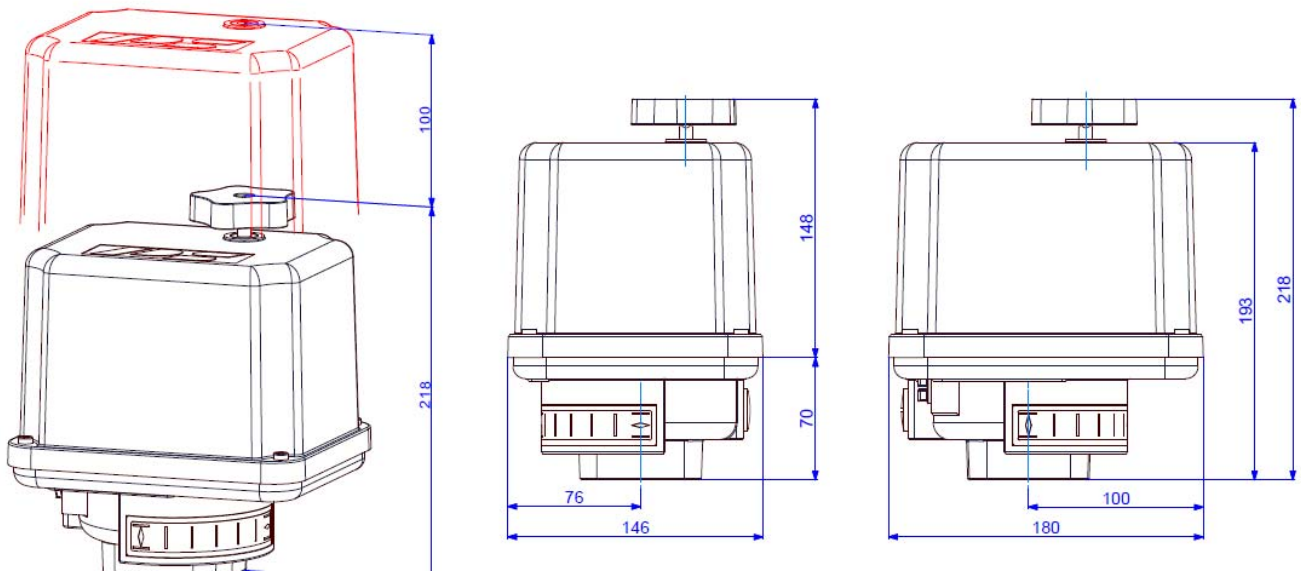

Figure 1: Installation dimensions PSR-E-C

Installation dimensions

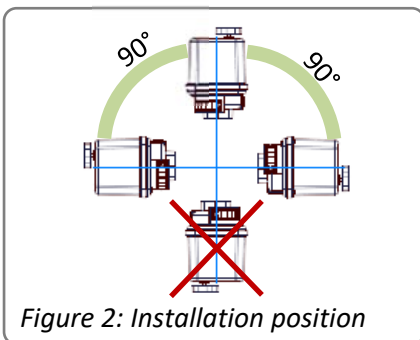

Figure 2: Installation position

Outdoor usage:



When using actuators in environments with high temperature fluctuations or high humidity, we recommend using a heating resistor.

The actuator may be mounted in any desired position except “cover facing downwards”.

6. Manual operation

The hand wheel allows manual operation in case of power failure or during adjustments (Mounting or positioning the valve). For manual operation, the hand wheel has to be pushed down against a spring.

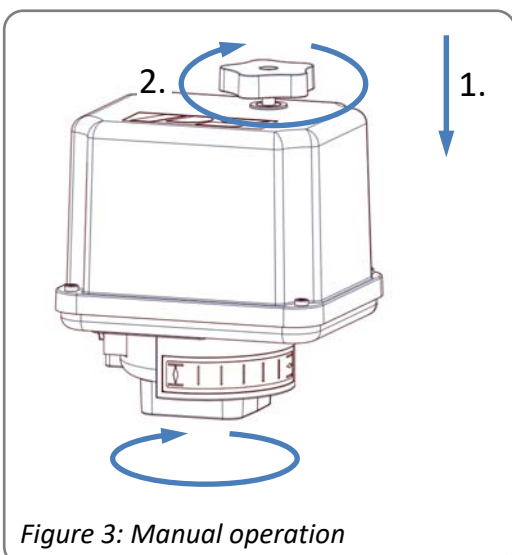

Figure 3: Manual operation



Do not exceed the adjusted electrical stroke limits. by handwheel.

The mechanical limits must be set accordingly.

Failure to observe this warning will change the electrical feedback setting!

7. Electric supply



Before connecting to mains, ensure that the mains supply is isolated and secured against an accidental switching-on.

Mains connection cables must be dimensioned suitably to accept the maximum current requirement of the actuator and correspond to IEC 227 and IEC 245.

The yellow-green coloured cables may be used only for connecting to earth.

When inserting cables through the cable connector, ensure that the maximum bending radius for the cable is observed.

PSR-E-C electric actuators do not have an internal electrical power switch. A switch or power mains switch has to be provided therefore in plant installation. This should be positioned close to the device and easily accessible to the user; it shall be labelled as the mains isolator switch for the actuator.

Electric installation as well as over-current and overvoltage protection devices must be conformed to the standard DIN VDE 0100-410:2007-06, protective class I resp. protection class 3 (24VAC/24VDC) and also to the standard DIN IEC 60364-4-44 according to the applied overvoltage category of the actuator.

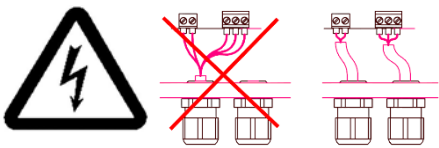

Please protect all of the power supply and control cables in front of the terminals mechanically by using suitable measures against unintentional loosening. Never install the power supply and the control cables together in one line but instead please always use two different lines.

7.1 Wiring diagram

Figure 4 shows the standard electrical connections. However, the wiring diagram inside the actuator hood is valid for the specific actuator. For any optional extras see the individual wiring diagram in the related service instructions.

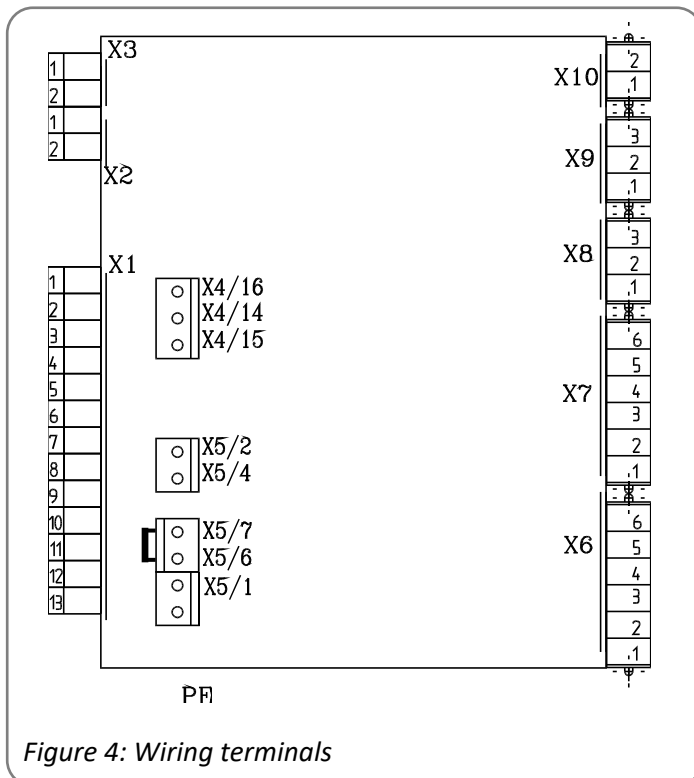

- X1 = Internal wiring
- X2 = Internal wiring
- X3 = Internal wiring
- X4 = Potentiometer 1 (for PSAP)
- X5/1 = Neutral
- X5/2 = Motor phase to open
- X5/4 = Motor phase to close
- X5/6 = Thermo switch as potential-free contact
- X5/7 = Thermo switch as potential-free contact
- X6 = Position signal switches
- X7 = not used
- X8 = Heating resistor
- X9 = Potentiometer 2
- X10 = not used
- PE = Earth connection on housing

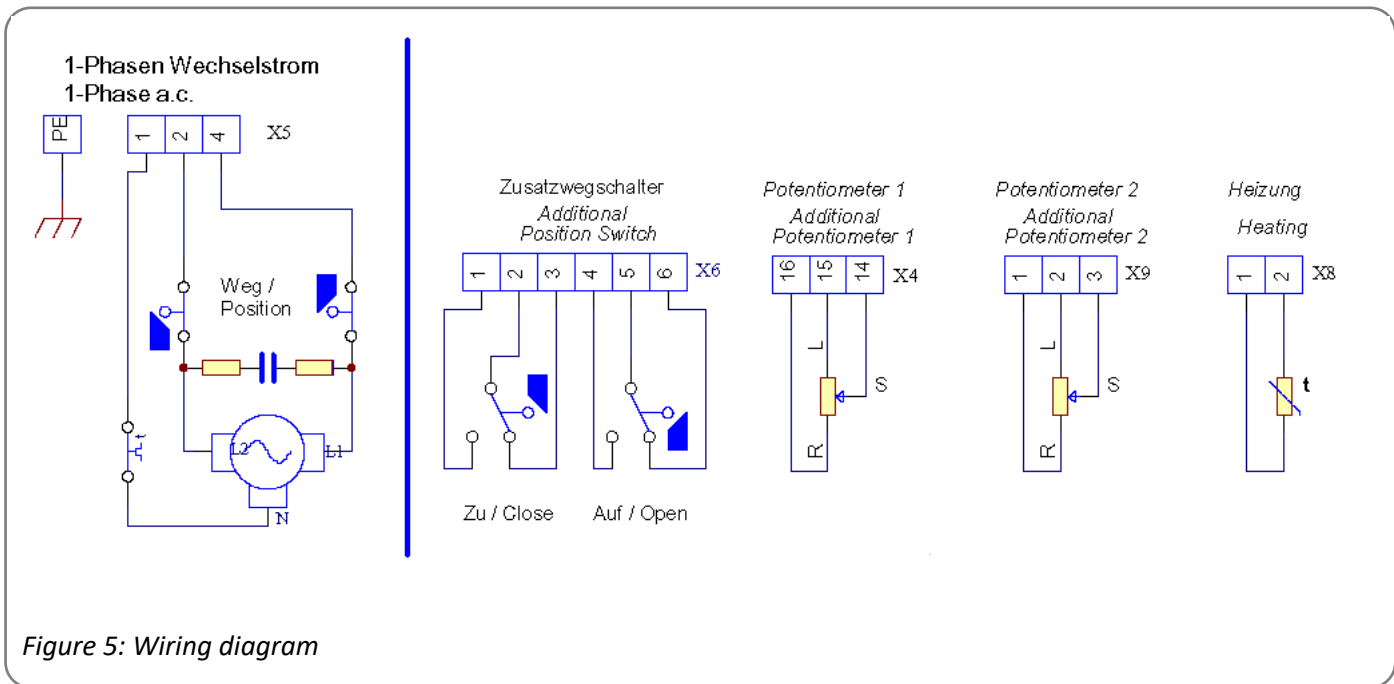

PE Earth connection on housing plate has to be connected!



Ensure that all connecting cables are stripped to the correct length so that they are protected against electric shock.

Two adjustable limit switches are installed to limit the stroke of the actuator, and cut-off the motor current in the relative direction.

Most motors have a thermal switch, depending on the actuator type, to cut off the current in both directions when a maximum temperature is reached (only at standard single phase power supply). The thermal switch loop is closed by the bridge between the X5/6 and X5/7 connections (see Figure 4).

7.2 Thermal switch as potential free contact

The thermo switch can be wired to the outside as follows:

- Remove the bridge between connections X5/6 and X5/7.
- Change the connections X1/11 and X1/13.
- Check conductivity between connections X5/6 and X5/7 (connection must be there).
- Connect the thermo switch as potential free contact to the connections X5/6 and X5/7.

Maximum thermal switch loading:

The thermo switch can be loaded up to the maximum nominal value for the motor (see motor nameplate).



When using the thermo switch as a potential-free contact, the switching signal must immediately stop the motor. Re-starting the motor is allowed only after the thermo switch has reset. Failure to observe this warning may result in damage to the actuator.

8. Valve mounting

The PSR-E-C actuators are designed with a mechanical interface according to ISO 5211 for valve mounting. The gear contains a double square SW17 to connect the actuator to the valve shaft.

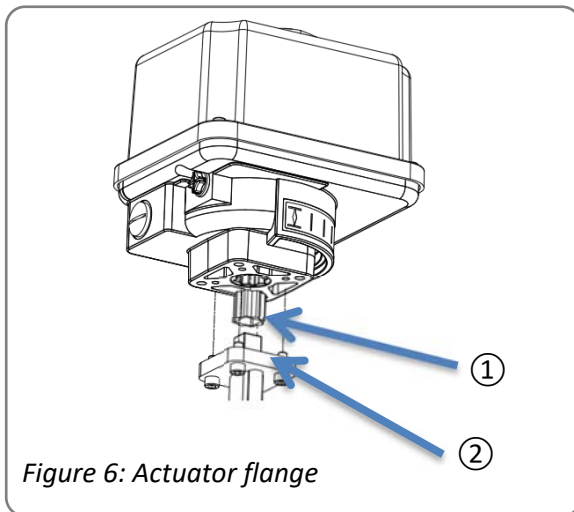

- Check that the actuator flange suits the valve flange.
- Use standard adapters to adapt to the valve shaft
- Clean the surface of the connection components, lubricate valve shaft slightly
- Position the actuator on the valve. Tighten the screws in a diagonal sequence according to the required torque.

Pos. ①: Actuator flange

Pos. ②: Drive bush

Figure 6: Actuator flange

9. Setting the mechanical stop

There is one adjustable screw available for setting the mechanical limit of the 90° angular stroke.



When setting the mechanical end positions, only the handwheel may be used. Do not operate the actuator electrically.

- Remove the protection cap (Figure 7; Pos. 2) from the stop screw.
- Back off the stop screw anti-clockwise approx. 5 turns.
- Move the actuator to the closed position by turning the handwheel clockwise.
- Turn stop screw for closed position (Figure 7, Pos. 1) finger tight, then a half turn back.
- Replace the protection cap onto the stop screw.

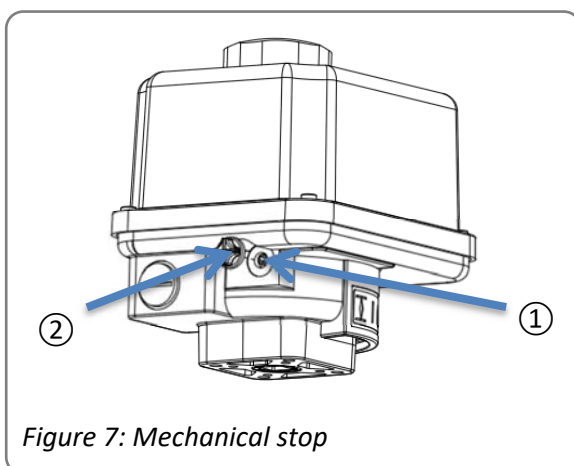

Pos. ①: Stop screw

Pos. ②: Protection cap

Figure 7: Mechanical stop

10. Adjustment of limit switches

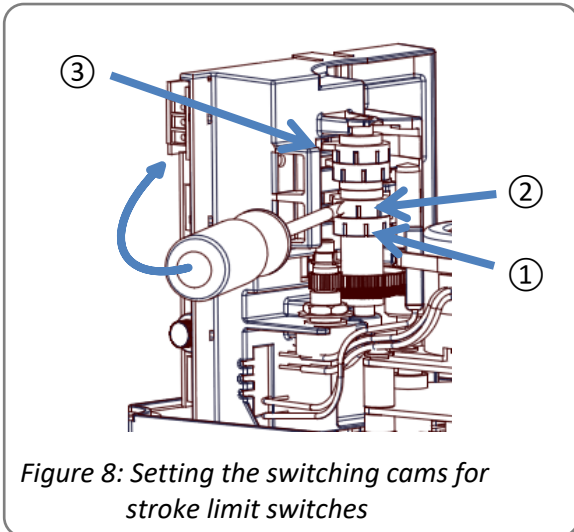

- Pos. ①: Switching cam CLOSE position
Pos. ②: Switching cam OPEN position
Pos. ③: Supporting bridge for screw driver

NOTE:

Use the bridge (Figure 8, Pos. 3) as support for the screw driver when adjusting the cams.

The standard limit switches serve to switch-off the motor when the end positions are reached.

Additional limit switches are free of voltage and serve to indicate the valve position. These are available as optional auxiliaries. The switches are activated by cams. These cams are stepless adjustable on their shaft by means of a friction coupling.



Ensure that the mains supply is secured against accidental switching-on!

- Run the actuator electrically to the closed position until the required position is reached.
- Turn the cam of the CLOSE limit switch (Figure 8, Pos. 1) with a suitable screw driver (4 mm blade width) anti-clockwise until the micro switch is heard to click.
- Run the actuator electrically to the open position until the required position is reached.
- Turn the cam of the OPEN limit switch (Figure 8, Pos. 2) with a suitable screw driver (4 mm blade width) clockwise until the micro switch is heard to click.

11. Commissioning

- Close the cover, re-install the handwheel.
- Drive the valve to an intermediate position using the handwheel.
- Switch the setting signal briefly between OPEN and CLOSE and ensure that the actuator operates in the correct direction either. If necessary, reverse the setting signal for OPEN/CLOSE.
- Drive the actuator in both directions, using the setting signal until the limit switch cuts-off. Ensure that the limit switch positions are correct. If necessary re-adjust the limit switches.



The electrical connection and commissioning with mains voltage applied may only be carried out by trained specialist personnel!

Do not touch any connection lines during commissioning!

12. Maintenance

The actuators are maintenance-free if used under the operating conditions as stated in the data sheet. The gearboxes are lubricated for lifetime and do not require further lubrication.



Caution!

During maintenance and repair the actuator must not be operated electrically.

12.1 Cleaning

The actuators should be cleaned dryly.

12.2 Spare parts

Defective actuators should be returned to our works in Bad Dürkheim, Germany, or to our representatives, for evaluation of failures and repair.

13. Decommissioning and disposal

- Disconnect the mains supply and ensure that it is secured against an accidental switching-on.
- Open the cover.
- Remove external electrical connections.
- Take off the actuator from the valve.

Disposal

For its disposal, the product should be treated as waste containing electrical and electronic equipment and should not be disposed of as household waste.



In accordance with 2012/19/EU on waste electrical and electronic equipment (WEEE), the devices described here may not be disposed of via municipal waste disposal companies.

If you are unable or unwilling to arrange for the equipment to be disposed of by a specialist company, you may return the equipment to the manufacturer, who will then ensure that the equipment is disposed of properly for a flat fee.

14. Appendix

14.1 Technical data and accessories

Please refer to the actuator data sheets for technical data.

Various auxiliaries are available in order to adapt the actuators to the various service conditions. A list of auxiliaries for each actuator type is shown on the actuator data sheet.

Mounting and start-up instructions are available separately for each accessory.



Standard switches with silver contacts are suitable for currents 100 mA to 5 A at voltages in the range of 24 V to 230 V AC/DC. For lower power up to 0,12 VA (0,1 mA to 100 mA at 1 V to 24 V AC/DC) we recommend switches with gold contacts (2WE Gold).

| Supply Voltage | | 230 VAC 1~ | 115 VAC 1~ | 24 VAC 1~ |
|-------------------------------|----------|----------------------------|------------|-----------|
| Position Signal Switches | 2WE | • | • | • |
| Position Signal Switches Gold | 2WE Gold | • | • | • |
| Positioner | PSAP | • | • | • |
| Position Transmitter | PSPT | • | • | • |
| Space Heating | HR | • | • | • |
| Potentiometer | PD | • | • | • |
| Increased Enclosure | IP | Increase to enclosure IP67 | | |

• = *available*

14.2 CE Declaration of Conformity

Declaration of Incorporation of Part Completed Machinery and EC Declaration of Conformity in compliance with the Directives on EMC and Low Voltage

We,

PS Automation GmbH
Philipp-Krämer-Ring 13
D-67098 Bad Dürkheim

Declare under our sole responsibility that we manufacture electric actuator series

**PSR-E...; PSQx03...; PSQ-E...; PSQ-AMS...; PSL-Mod.4...;
PSL-AMS...; PSF...; PSF-M...; PSF-Q...; PSF-Q-M...**

according the requirements of the

EC Directive 2006/42/EC

as part completed machinery. These actuators are designed to be installed on industrial valves.
It is prohibited to take the actuator into service until it has been ensured that the complete machine conforms
the applicable machinery directives.

The technical documentation described in Annex VII, part B has been prepared.

The above actuators further comply with the requirements of the following directives.

| | |
|---------------------------------|--|
| 2014/30/EU | Electromagnetic Compatibility (EMC) |
| 2014/35/EU | Low Voltage (LVD) |
| 2011/65/EU + 2015/863/EU | Restriction of Hazardous Substances (RoHS) |

furthermore, the following harmonised standards have been applied:

| | |
|---------------------------|---|
| EN 61000-6-2: 2005 | Electromagnetic compatibility (EMC), Generic standards- Immunity for industrial environments |
| EN 61000-6-3: 2007 | Electromagnetic compatibility (EMC), Generic standards- Emission standard for residential, commercial and light-industrial environments |
| EN 61010-1: 2020 | Safety Requirements for Electrical Equipment for Measurement, Control and Laboratory use |

Bad Dürkheim, 2022



Christian Schmidhuber
(General Manager)

CAUTION!

To ensure compliance of these actuators with the above directives, it is the responsibility of the specifier, purchaser, installer and user to observe the relevant specifications and limitations when taking the product into service. Details are available on request, and are mentioned in the Installation and Maintenance Instructions.

14.3 CA Declaration of Conformity

Declaration of Incorporation of Part Completed Machinery and CA Declaration of Conformity in compliance with the Legislation on EMC and Low Voltage

We,

**PS Automation GmbH
Philipp-Krämer-Ring 13
D-67098 Bad Dürkheim**

Declare under our sole responsibility that we manufacture electric actuator series

PSR-E...; PSQx03...; PSQ-E...; PSQ-AMS...; PSL-Mod.4...; PSL-AMS...; PSF...; PSF-M...

according to the requirements of the

2008 No. 1597

Supply of machinery (safety) regulations

as part completed machinery. These actuators are designed to be installed on industrial valves.

It is prohibited to take the actuator into service until it has been ensured that the complete machine conforms to the applicable machinery legislation.

The technical documentation described in Annex VII, part B has been prepared.

The above actuators further comply with the requirements of the following legislations:

**UK SI 2016 No. 1091 and
Amendments**

The Electromagnetic Compatibility Regulations 2016

**UK SI 2016 No. 1101 and
Amendments**

The Electrical Equipment (Safety) Regulations 2016

**UK SI 2012 No. 3032 and
Amendments**

**The Restriction of the Use of Certain Hazardous Substances in
Electrical and Electronic Equipment Regulations 2012**

the provisions of the legislations and their compliance are given by the following named standard(s), which have been applied:

EN 61000-6-2: 2005

Electromagnetic compatibility (EMC), Generic standards-
Immunity for industrial environments

EN 61000-6-3: 2007

Electromagnetic compatibility (EMC), Generic standards-
Emission standard for residential, commercial
and light-industrial environments

EN 61010-1: 2020

Safety Requirements for Electrical Equipment for
Measurement, Control and Laboratory use

Bad Dürkheim, 2021



Christian Schmidhuber
(General Manager)

CAUTION!

To ensure compliance of these actuators with the above directives, it is the responsibility of the specifier, purchaser, installer and user to observe the relevant specifications and limitations when taking the product into service. Details are available on request, and are mentioned in the Installation and Maintenance Instructions.

Our representatives:

Italy

PS Automazione S.r.l.
Via Pennella, 94
I-38057 Pergine Valsugana (TN)
Tel.: <+39> 04 61-53 43 67
Fax: <+39> 04 61-50 48 62
E-mail: info@ps-automazione.it

India

PS Automation India Pvt. Ltd.
Srv. No. 25/1, Narhe Industrial Area,
A.P. Narhegaon, Tal. Haveli, Dist.
IND-411041 Pune
Tel.: <+ 91> 20 25 47 39 66
Fax : <+ 91> 20 25 47 39 66
E-mail : sales@ps-automation.in
www.ps-automation.in

To find out more about all our sales partners and subsidiaries please scan the QR code below or visit our website:

<https://www.ps-automation.com/locations/?lang=en>



PS Automation GmbH

Philipp-Krämer-Ring 13
D-67098 Bad Dürkheim

Phone: +49 (0) 6322 94980-0
E-mail: info@ps-automation.com
www.ps-automation.com

