

Operating Instructions

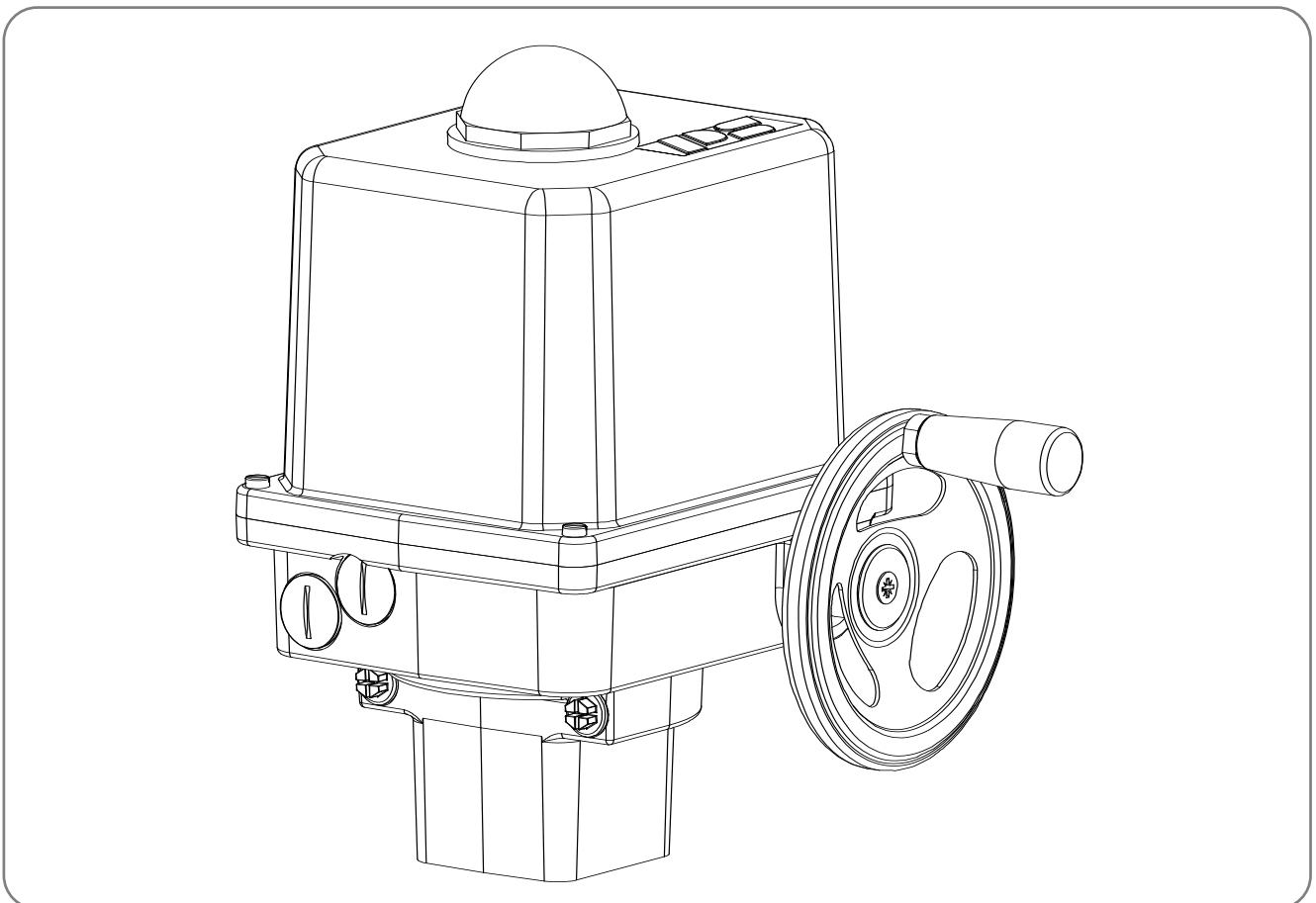

Contents

- Type key 2
- 1. Symbols and safety 3
- 2. Usage as per specification 4
- 3. Storage 4
- 4. Operational conditions 4
 - 4.1 Installation position 5
- 5. Function 6
- 6. Manual operation 6
- 7. Valve mounting 7
 - 7.1 Valve mounting PSQ103-1503 7
 - 7.2 Valve mounting PSQ2003/2803 7
- 8. Setting the mechanical stops 8
 - 8.1 Setting the mechanical stops PSQ103-1503 8
 - 8.2 Setting the mechanical stops PSQ2003/2803 8
 - 8.3 Adjustment of the position indicator 9
- 9. Setting the position switches 9
- 10. Setting the torque limit 10
- 11. Electric supply 12
 - 11.1 Wiring diagram 13
- 12. Commissioning 14
- 13. Service/maintenance 15
 - 13.1 Cleaning 15
 - 13.2 Spare parts 15
- 14. Safety on Transportation 15
- 15. Decommissioning and disposal 15
- 16. Appendix 16
 - 16.1 Accessories 16
 - 16.2 EC Declaration of Conformity 17
 - 16.3 CA Declaration of Conformity 18

Type key

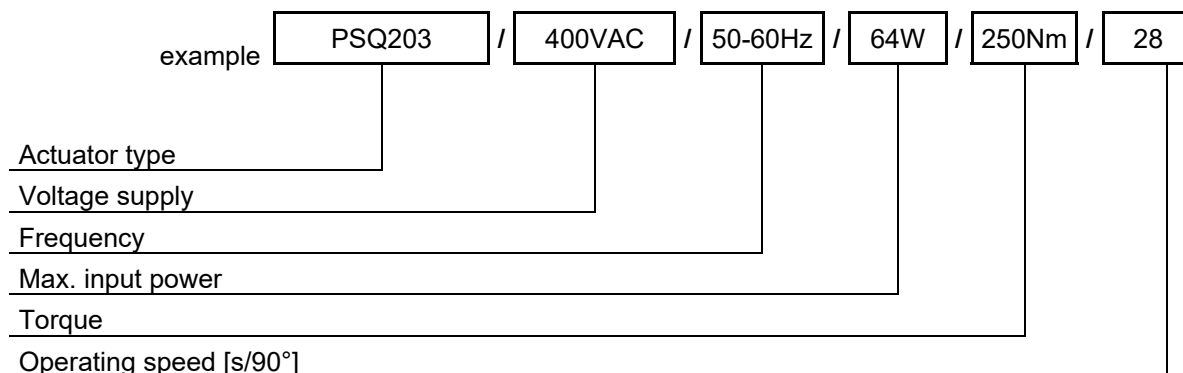

1. Symbols and safety

Dangers of non-compliance with safety regulations

PSQx03 actuators are built to state-of-the-art technology and are safe to operate. Despite this, the actuators may be hazardous if operated by personnel that has not been sufficiently trained or at least instructed, and if the actuators are handled improperly, or not used as per specification.

This may

- cause danger to life and limb of the user or a third party,
- damage the actuator and other property belonging to the owner,
- reduce safety and function of the actuator.

To prevent such problems, please ensure that these operating instructions and the chapter on "1. Symbols and safety" in particular have been read and understood by all personnel involved in the installation, commissioning, operation, maintenance and repair of the actuators.

Basic safety notes

- The actuators may only be operated by skilled and authorized operating personnel.
- Make sure to follow all security advices mentioned in this manual, any national rules for accident prevention, as well as the owner's instructions for work, operation and safety.
- The isolating procedures specified in these operating instructions must be followed for all work pertaining to the installation, commissioning, operation, change of operating conditions and modes, maintenance, inspection, repair and installation of accessories.
- Before opening the actuator cover, ensure that mains supply is isolated and prevented from unintended re-connection.
- Areas that can be under voltage have to be isolated before working on them.
- Ensure that the actuators are always operated in faultless condition. Any damage or faults, and changes in the operational characteristics that may affect safety, must be reported at once.

Danger signs

The following warning symbols are used in this manual:



Caution! There is a general risk of damage to health and/or properties.



Danger! Electrical voltages may be present that are dangerous to life!

Other notes

- The motor surface may have elevated temperature when servicing, inspecting or repairing it immediately after operation. Danger of burning the skin!
- Always observe the relevant operating instructions when fitting PS accessories or operating the actuator with PS accessories.
- Connections for signal in- and output are double isolated from circuits that can be under dangerous voltage.

2. Usage as per specification

- The PSQx03 quarter turn actuators are exclusively designed as electric valve actuators. They are meant to be mounted on valves for motor operation.
- Any other use is considered to be not in accordance to standard specification, and the manufacturer cannot be held liable for any damage resulting from it.
- The actuators may not be used outside the limits laid out in data sheets, catalogues and order documentation. Otherwise the manufacturer cannot be held liable for any resulting damage.
- Usage as per specification includes the observance of the operating, service and maintenance conditions laid down by the manufacturer.
- Not to be regarded as usage as per specification are mounting and adjustment of the actuator, and servicing. Special precautions have to be taken while doing this!
- The actuators may only be used, serviced and repaired by personnel that are familiar with them and informed about potential hazards. The specific regulations for the prevention of accidents have to be observed.
- Damages caused by unauthorized modifications carried out on the actuators are excluded from the manufacturer's liability.
- Supply voltage may be switched on only after properly closing the main cover or terminal box.

3. Storage

The following must be observed with regards to proper storage:

- Only store the actuators in ventilated, dry rooms.
- Store the actuators on shelves, wooden boards etc. to protect them from soil moisture.
- Cover the actuators with plastic foil to protect them from dust and dirt.
- Protect the actuators against mechanical damage.

4. Operational conditions

- Actuators with synchronous motors can fluctuate by up to +/-20% in the actuating force with +/-10% voltage fluctuation.
- The standard actuators can be operated at ambient temperatures from -20°C to +80°C.
- Ambient temperature range for modulating duty is from -20°C to +60°C.
- The operating modes correspond to IEC 60034-1, 8: S2 for 3-point operation, and S4 for control duty (For protection against moisture and dust, the actuator enclosure rating is IP67 / IP68 according to EN 60529.) To ensure the protection rating, the cover must be fitted correctly and the holding screws tightened crosswise. The cable glands must be suitable for the cables and correctly fitted to the actuator.
- When installing the actuators, leave enough space to permit cover removal (Figure 1: Installation dimensions).
- Any installation position is allowed except "cover pointing downwards" (Figure 2: Installation position).

PSQ103-1503

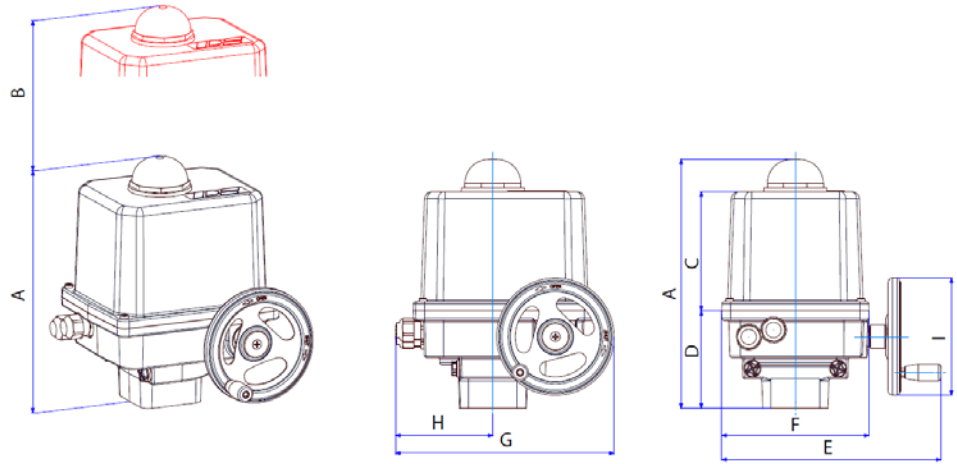

PSQ2003-2803

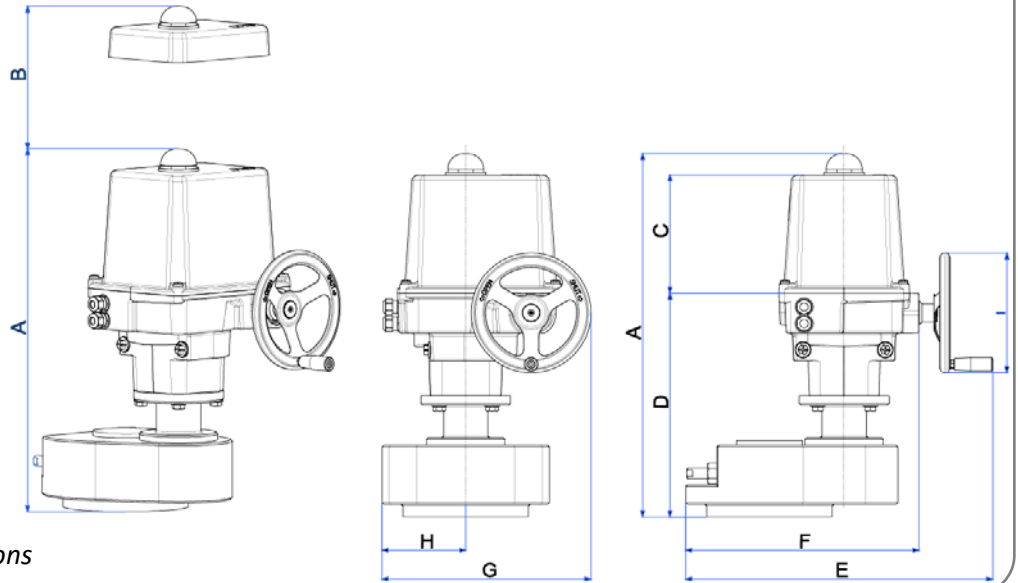

Figure 1: Installation dimensions

Dimensions	A	B	C	D	E	F	G	H	I
PSQ103	268	161	128	104,5	236	158	244	114	125
PSQ203	355	228	194	122,5	307	185	292	112	200
PSQ503/703	406	240	198	171,5	358	234	350	141	200
PSQ1003	406/409	240	198	171,5	287	234	375	141	250
PSQ1503	406/409	240	198	173	275	234	375	141	250
PSQ2003/2803	608	240	198	374,5	514	390	350	140	200

4.1 Installation position

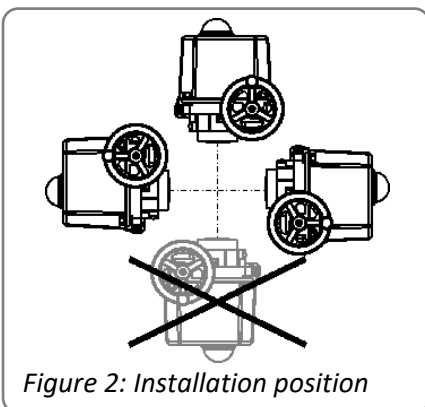

Figure 2: Installation position

Outdoor usage



When using actuators in environments with high temperature fluctuations or high humidity, we suggest a heating resistor and an increased IP protection to be fitted to prevent the build-up of condensation within the enclosure (accessories).

5. Function

The electric quarter-turn actuators series PSQx03 are designed to operate valves with 90° motion. The PSQ actuators are provided with a mechanical interface according to ISO 5211 for valve mounting. The motor torque is transmitted via a spur gear onto the sun wheel of a „Wolfrom“-gear. The rotating output wheel of the „Wolfrom“-gear holds a removable drive bush to connect the actuator with the valve stem. Two adjustable position switches are limiting the electrical motion in both directions by interrupting the motor current or control circuit when reaching the adjusted position.

The 90° motion is mechanically adjustable by +/- 5° by means of two stop screws. Torque switches are installed for each direction.

The handwheel does allow comfortable manual operation in case of power failure or for commissioning. The handwheel is idle when the motor is operating the actuator, but engaged in any position without clutching or declutching.

Electrical wiring is done to a terminal block under the actuator cover.

6. Manual operation

The actuators are supplied with a loosely enclosed handwheel. Mount the handwheel and the crank according to Figure 3:

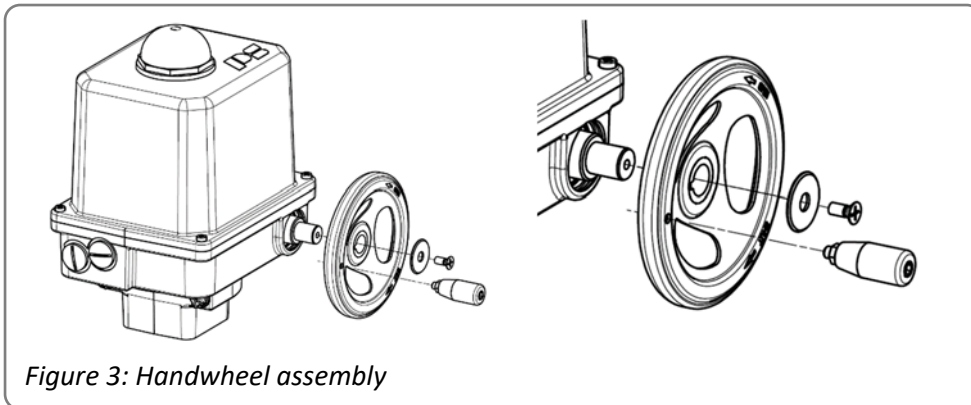

Figure 3: Handwheel assembly

The handwheel does provide manual operation in case of power failure or commissioning (valve mounting and setting of end positions). It is idle when the motor is operating and always ready for operation without clutching or declutching.

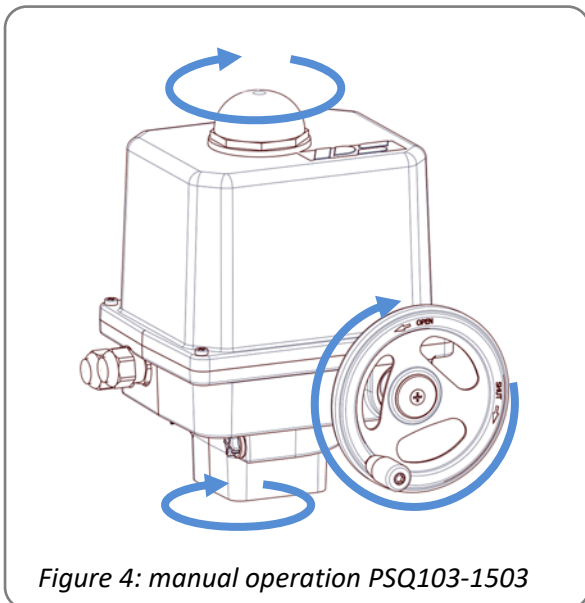

Figure 4: manual operation PSQ103-1503

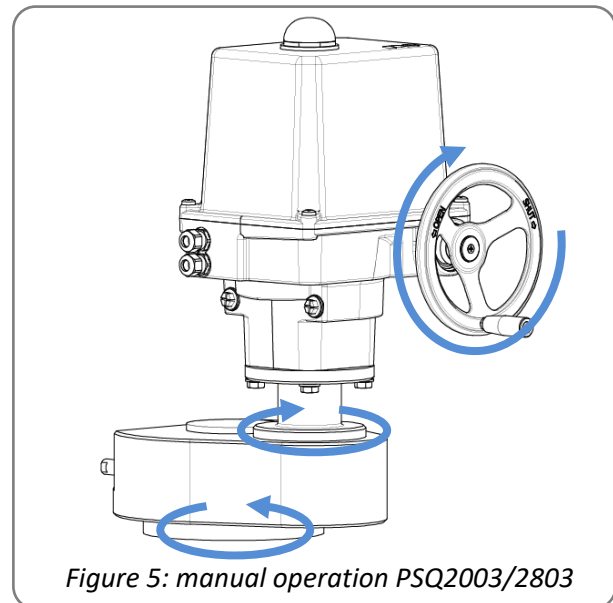

Figure 5: manual operation PSQ2003/2803



**Do not exceed the adjusted electrical stroke limits by handwheel.
The mechanical limits must be set accordingly.
Failure to observe this warning will change the electrical feedback setting!**

7. Valve mounting

7.1 Valve mounting PSQ103-1503

The PSQx03 actuators are provided with flanges according to ISO 5211 for valve mounting. Connection to the valve shaft is made with an exchangeable drive bush.

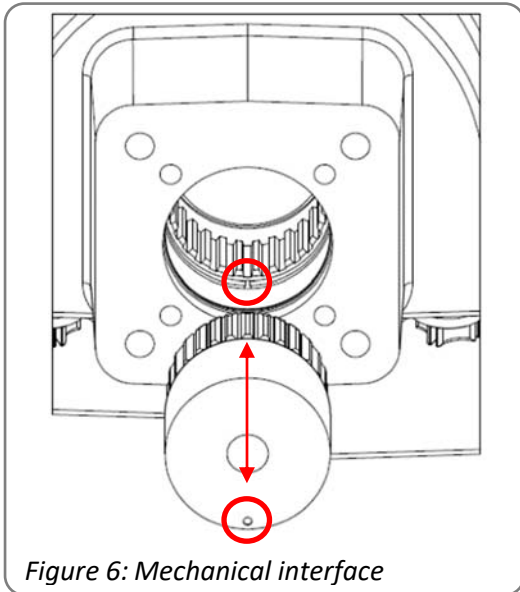

Figure 6: Mechanical interface

Starting position: drive bush is already pre-installed in the actuator

- Ensure the correct position of the actuator by position indicator and adapt it to the position of the valve by handwheel. Ideally, the end position of the valve should be open or closed. Drive the actuator in the same end position by handwheel.
- If the positions of valve and actuator are adapted, put the actuator with the drive bush on the valve.
- Adapt the accurate mounting position by handwheel to insert the screws in the mounting flange. Tighten the screws in a diagonal sequence.

Starting position: drive bush is delivered separately and not yet pre-installed in the actuator

- Put the drive bush on the valve shaft first.
- Follow the instructions of the pre-installed drive bush above. However, please note: The drive bush is not installed in the actuator for mounting on the valve shaft. Instead, the drive bush is already mounted on the valve shaft as a unit. Put the actuator on this unit.

7.2 Valve mounting PSQ2003/2803

The PSQx03 actuators are provided with flange F16 according to ISO 5211 for valve mounting. Connection to the valve shaft is made with a 55 mm double square. Delivery of the actuator includes two components: the gearbox and the actuator itself. They are mounted on the valve one after the other.



For valve mounting please ensure that the cover of the actuator is always closed in order to avoid that components inside the actuator are damaged.

- Ensure the correct position of the gearbox by position indicator and adapt it to the valve position using a 22 mm spanner to turn the shaft of the gearbox. In the best case, the position of the valve should be open or closed during mounting. If possible, drive the valve to one of the end positions manually. Drive the gearbox in the same end position using the spanner.
- If the gearbox and actuator are in the same position, mount the gearbox on the valve (if necessary, mount the adaptation of the valve shaft on the 55 mm double square first).
- Adapt the accurate mounting position with the spanner in order to insert the screws in the mounting flange. Tighten the screws in a diagonal sequence.
- Put either (A) the actuator with the drive bush on the gearbox or (B) at first the drive bush and then the actuator on the gearbox (see figure 6 for reference).
- Adapt the accurate mounting position by handwheel to insert the screws in the mounting flange. Tighten the screws in a diagonal sequence.

8. Setting the mechanical stops

There are two adjustable screws installed at the actuator / gearbox for setting the mechanical limit of the 90° motion.



When setting the mechanical end positions, only the handwheel may be used. Do not operate the actuator electrically.

8.1 Setting the mechanical stops PSQ103-1503

- Remove the protection cap (Figure 7, item 3) from either stop screw.
- Unscrew both hexagon sockets anti-clockwise by approximately 5 turns.
- Move the actuator to the closed position by turning the handwheel clockwise.
- Turn stop screw for closed position (Figure 7, item 1) to the stop.
- Move the actuator to the open position by turning the handwheel anti-clockwise.
- Turn stop screw for open position (Figure 7, item 2) to the stop.
- Screw on protection cap.

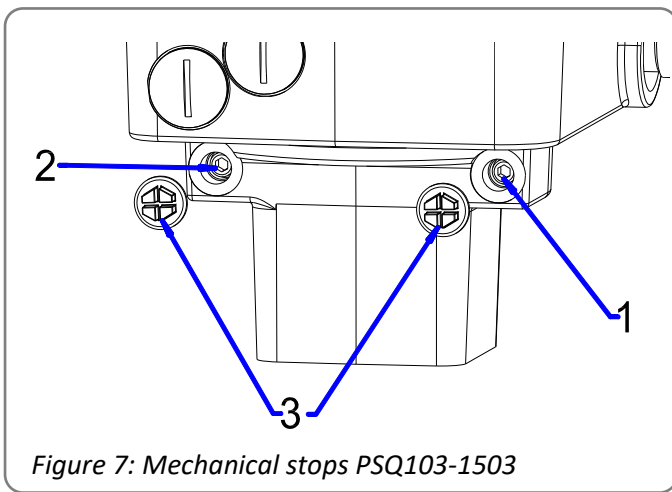

Item 1: Stop screw CLOSED position
Item 2: Stop screw OPEN position
Item 3: Protecting caps

8.2 Setting the mechanical stops PSQ2003/2803

- Unscrew both hexagon sockets anti-clockwise by approximately 5 turns.
- Move the actuator to the closed position by turning the handwheel anti-clockwise.
- Turn stop screw for closed position (Figure 8, item 1) to the stop.
- Move the actuator to the open position by turning the handwheel clockwise.
- Turn stop screw for open position (Figure 8, item 2) to the stop.
- Tighten hexagon nuts.

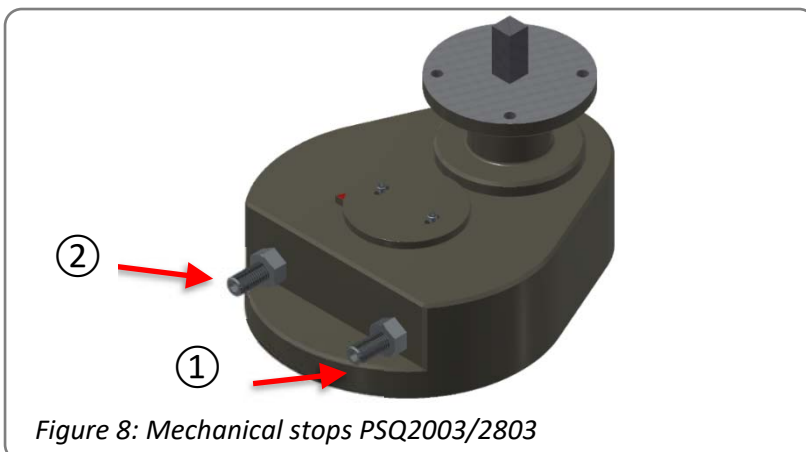

Item 1: Stop screw CLOSED position
Item 2: Stop screw OPEN position

8.3 Adjustment of the position indicator

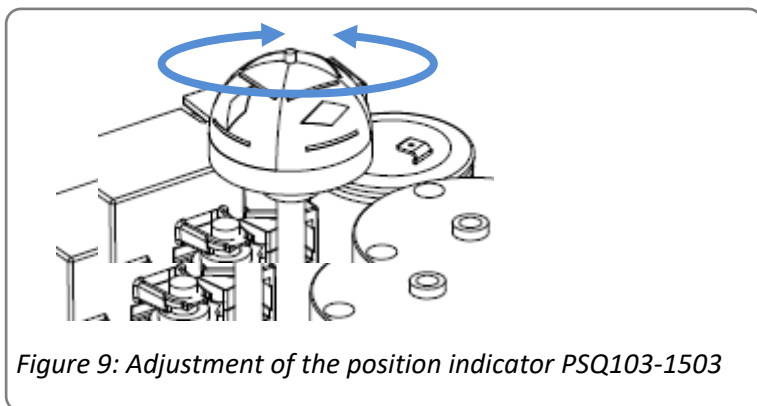

PSQ103-1503

The position indicator is a two-coloured half ball turning under a transparent dome with blackened quarter segments.

Take off the cover and turn the half ball as appropriate to adjust the position indicator.

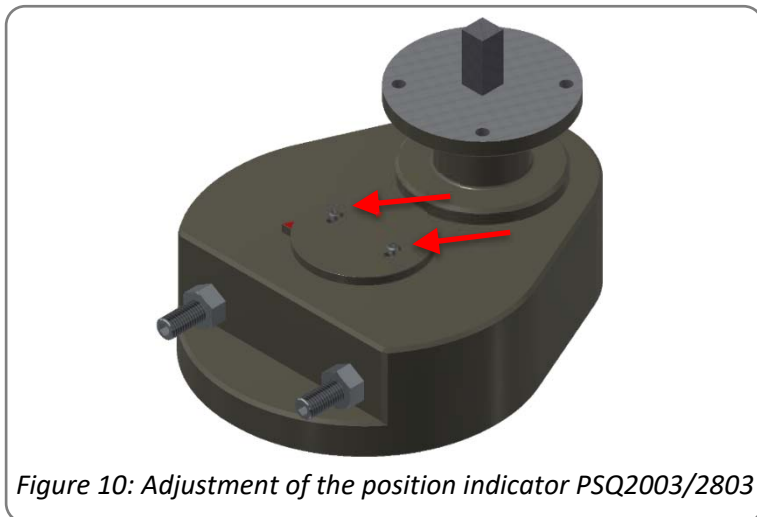

PSQ2003/2803

The position indicator is installed on the gearbox.

Unscrew both hexagon sockets to adjust the position indicator. Finally, tighten the screws.

9. Setting the position switches

The standard position switches serve to switch off the motor when the desired limits are reached. Additional position switches are potential-free opening/closing contacts and serve to indicate the valve position. They are available as accessories. The switches are activated by cams. These cams are stepless adjustable on their shaft by means of a friction coupling.

NOTE:

Use the bridge in figure 11, item 3 as support for the screw driver when adjusting the cams.

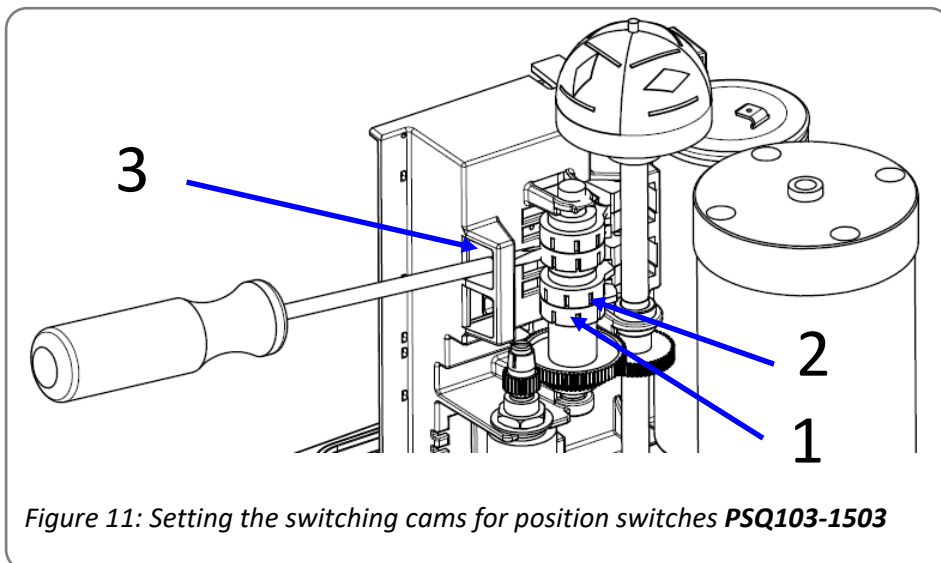

Item 1:
Switching cam CLOSE position

Item 2:
Switching cam OPEN position

Item 3:
Bridge for screw driver support

Figure 11: Setting the switching cams for position switches **PSQ103-1503**

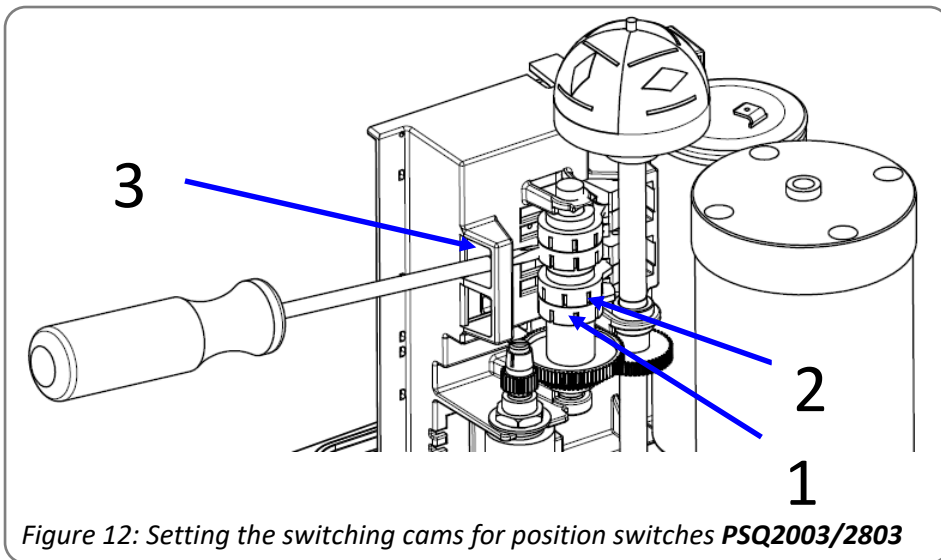

Item 1:
Switching cam OPEN position

Item 2:
Switching cam CLOSE position

Item 3:
Bridge for screw driver support

Figure 12: Setting the switching cams for position switches **PSQ2003/2803**



Ensure that the mains supply is secured against accidental switching-on!

- Run the actuator electrically to the closed position until the valve is closed and the actuator is switched off by the torque switch.
- Turn the cam of the CLOSE position switch (Figure 11, item 1 and Figure 12, item 2) with an isolated screw driver (4 mm blade width) anti-clockwise until the micro switch is heard to click.
- Run the actuator electrically to the open position until the valve is fully open and the actuator is switched off by the torque switch.
- Turn the cam of the OPEN position switch (Figure 11, item 2 and Figure 12, item 1) with an isolated screw driver (4 mm blade width) clockwise until the micro switch is heard to click.
- Drive the actuator away from either end position to release the stop screws.
- Turn both stop screws counter-clockwise by one turn.
- Replace protection caps (Figure 7, item 3) onto the stop screw holes after setting the position switches.

10. Setting the torque limit

There is one torque switch installed for each direction that cuts off the motor current when operated (single phase motors).

The quarter-turn actuator is set and checked by the manufacturer in order to limit the actuator to the nominal torque in both directions. The reduction of the maximum output torque is possible by setting the switch brackets, to suit the specific requirements of the valve.

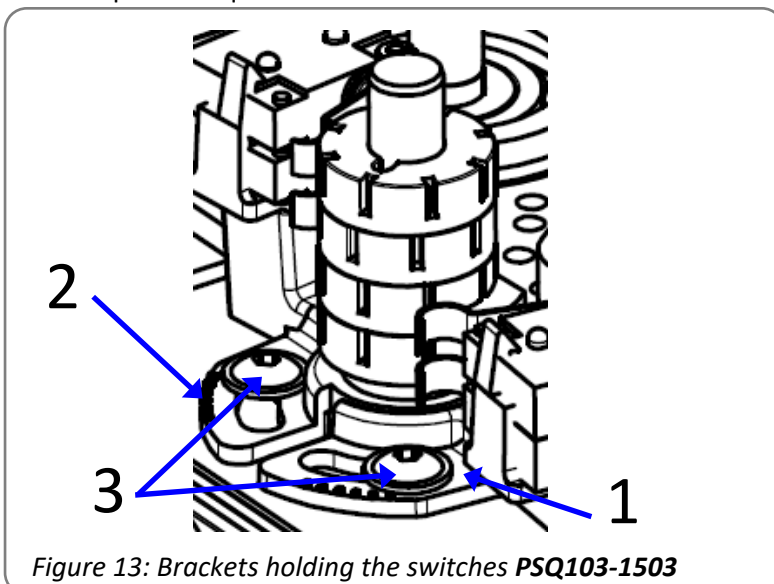

- Loosen the torque setting screws (Figure 13, item 3) and turn the switch brackets to the required position.
- Fix these positions by tightening the screws.

Item 1: Switch bracket „CLOSE“

Item 2: Switch bracket „OPEN“

Item 3: Fixing screws

Figure 13: Brackets holding the switches **PSQ103-1503**

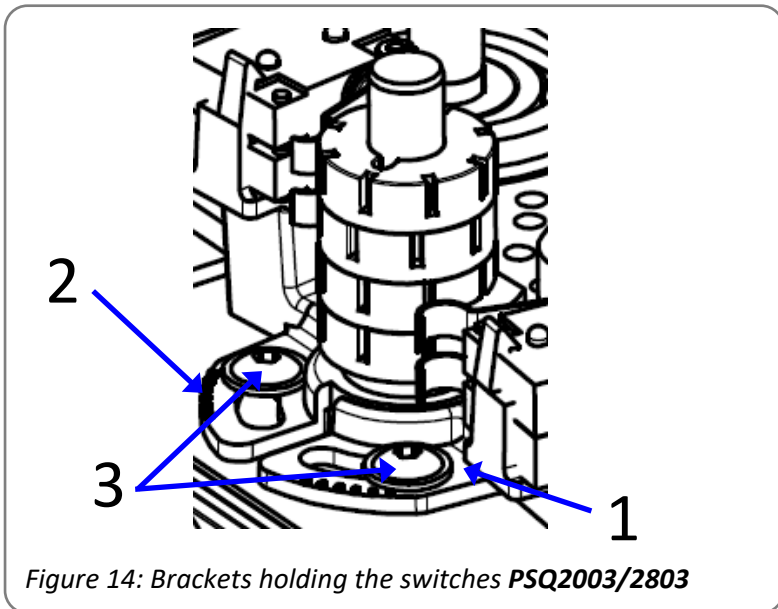

- * Loosen the torque setting screws (Figure 14, item 3) and turn the switch brackets to the required position.
- * Fix these positions by tightening the screws.

Item 1: Switch bracket „OPEN“
 Item 2: Switch bracket „CLOSE“
 Item 3: Fixing screws

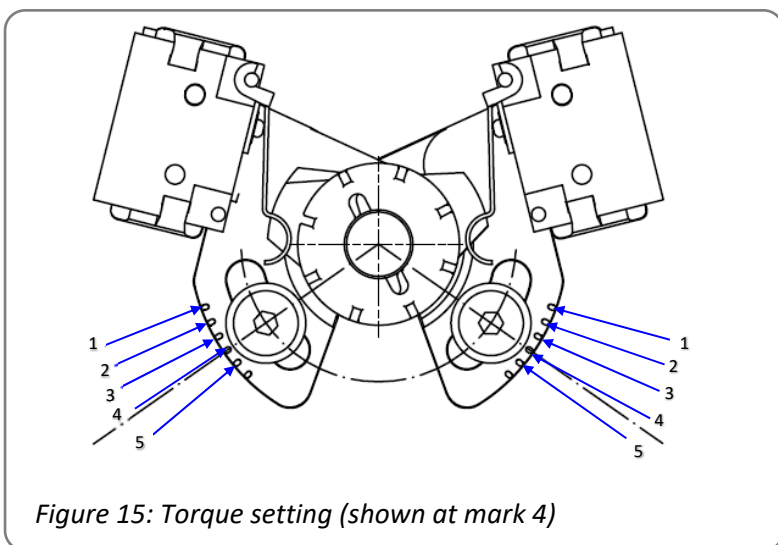

There are marks on both switch brackets.

When moving those marks against the center of the set screw, the following torque adjustments can be achieved (Figure 15):

	PSQ103	PSQ203	PSQ503	PSQ703	PSQ1003	PSQ1503	PSQ2003	PSQ2803	PSQ3003
Mark	Torque	Torque	Torque	Torque	Torque	Torque	Torque	Torque	Torque
End position	100%	100%	100%	100%	100%	100%	100%	100%	100%
1	90%	85%	85%	-	90%	85%	85%	-	90%
2	80%	70%	75%	85%	75%	70%	75%	85%	75%
3	70%	55%	60%	75%	65%	55%	60%	75%	65%
4	60%	-	50%	65%	55%	-	50%	65%	55%
5	50%	-	-	55%	-	-	-	55%	-

11. Electric supply



Before connecting to mains, ensure that the mains supply is isolated and secured against an accidental switching-on.

The mains connecting cables must be suitably dimensioned to accept the maximum current requirement of the actuator, and correspond to IEC 227 and IEC 245. The yellow-green coloured cables may only be used for connecting to earth.

When inserting the cable through the cable connector, ensure that the maximum bending radius for the cable is observed.

The PSQx03 electric actuators do not have an internal electrical power switch. Therefore, a power mains switch has to be provided for installation. It should be positioned close to the device and be easily accessible to the user and shall be labelled as the mains isolator switch for the actuator.

Electric installation as well as over-current and overvoltage protection devices must be conformed to the standard DIN IEC 60364-4-41, protective class I resp. protection class 3 (24 VAC/24 VDC) and also to the standard DIN IEC 60364-4-44 according to the applied overvoltage category of the actuator.



Please protect all of the power supply and control cables in front of the terminals mechanically by using suitable measures against unintentional loosening. Never install the power supply and the control cables together in one line but instead please always use two different lines.

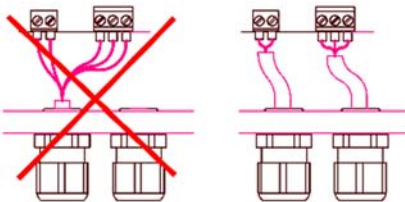

11.1 Wiring diagram

Figure 16 indicates the wiring diagrams for standard actuators. However, the wiring diagram inside the actuator cover is relevant for the specific actuator. See the separate wiring diagram in the corresponding service instructions for any set of accessories.

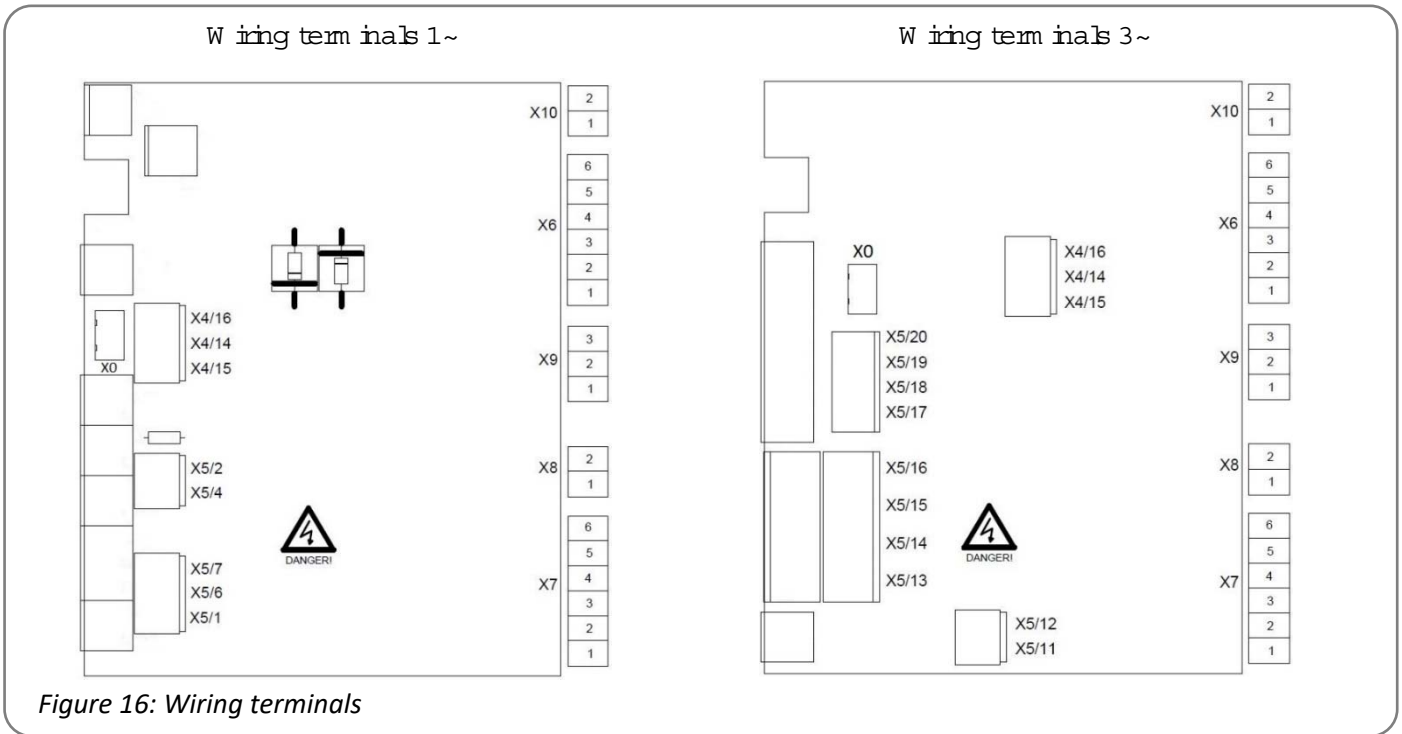

Figure 16: Wiring terminals

X0 = Potentiometer, internal wiring
 X10 = Normally OPEN contact option

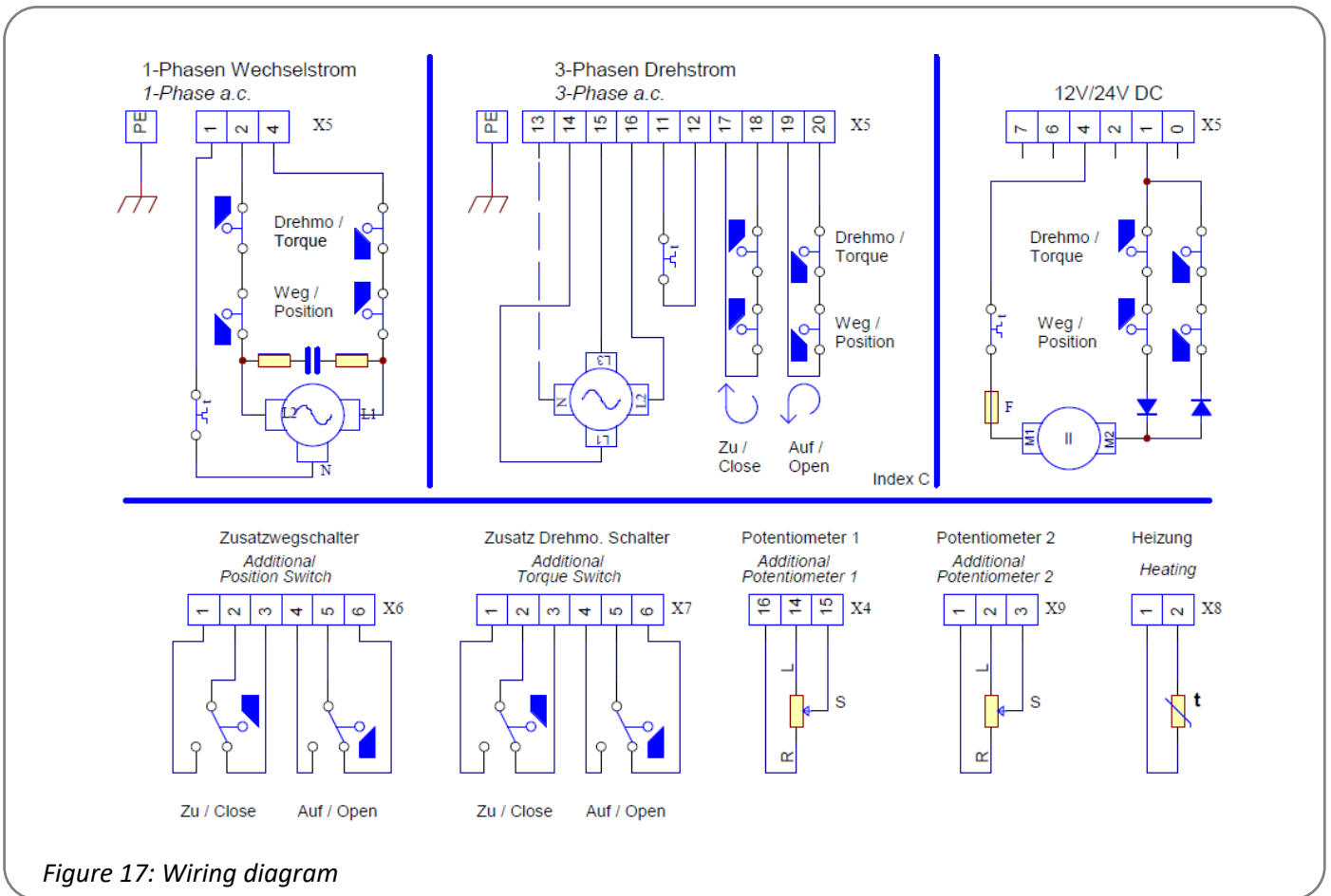

Figure 17: Wiring diagram



PE Earth connection on housing plate has to be connected! 

The connection for potential equalisation is made to the external potential equalisation connection of the drive.

Ensure that all connecting cables are stripped to the correct length so that they are protected against electric shock.

With 3-phase three-phase current, the internal limit/torque switches must be wired by the customer for disconnection! This does not apply when using a reversing contactor integrated in the drive (optional).

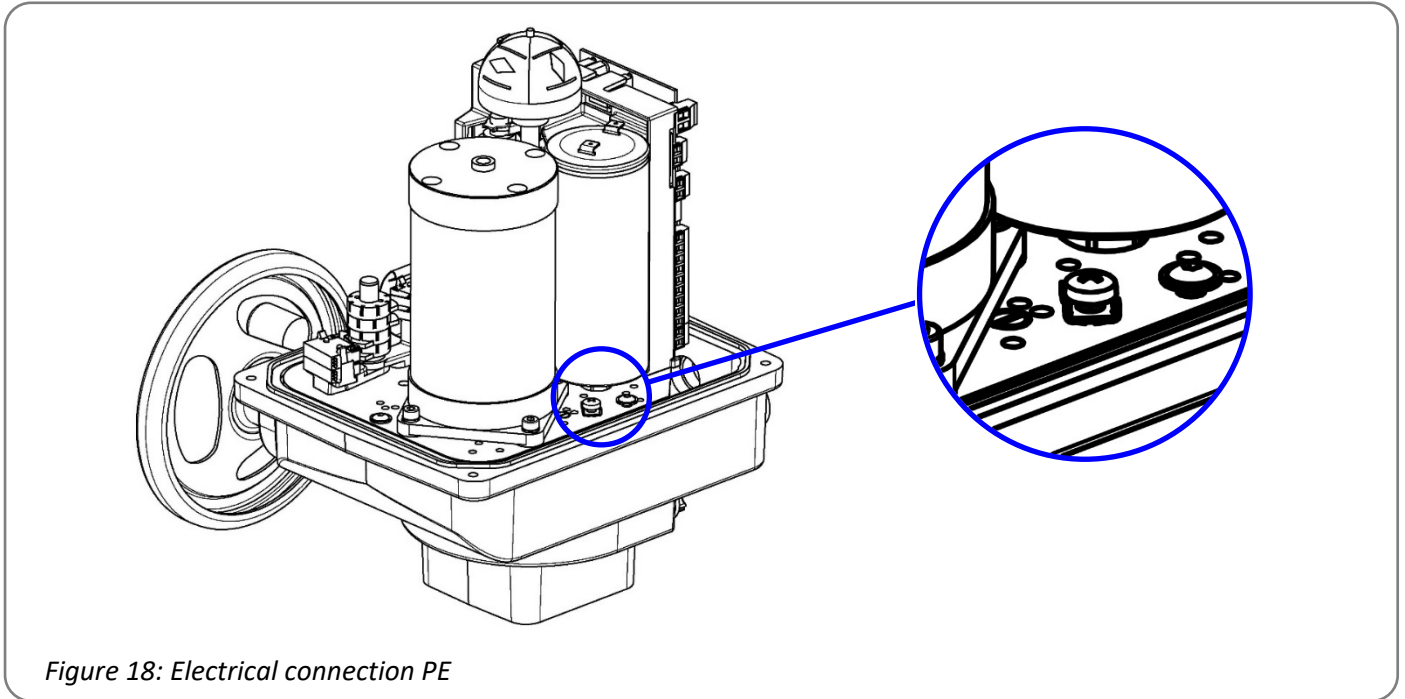

Figure 18: Electrical connection PE

Two adjustable position switches are installed to limit the stroke of the actuator, and cut-off the motor current in the relative direction.

Most motors have a thermal switch, depending on the actuator type, to cut off the current in both directions when a maximum temperature is reached (only at standard single-phase power supply).

12. Commissioning

- Close the cover.
- Turning the handwheel, drive the valve to the middle position.
- Switch the setting signal briefly to OPEN and CLOSE and check that the actuator operates in the correct direction. If necessary, reverse the setting signal for OPEN/CLOSE.
- Drive the actuator in either direction, using the setting signal until the position switch cuts-off. Check that the position switch setting is correct. If necessary re-adjust the position switch (see chapter 9).



The electrical connection and commissioning with mains voltage applied may only be carried out by trained specialist personnel!

Do not touch any connection lines during commissioning!

13. Service/maintenance

The actuators are maintenance-free if used under the operating conditions as established in the data sheet. The gearboxes are lubricated for life and do not require further lubrication.



Caution!
During maintenance and repair the actuator must not be operated electrically.

13.1 Cleaning

The actuators should be cleaned with dry cloth.

13.2 Spare parts

PSQx03 actuators are very robust functional units. In case of malfunction or damage of any component, spare parts are available as per a separate spares price list. Please contact PS Automation GmbH or the appropriate representative.

Damaged actuators can be returned to our plant in Bad Dürkheim, Germany, or to our representatives, for evaluation of failures and repair.

14. Safety on Transportation

For transportation and storage all cable glands and connection flanges have to be closed to prevent ingress of moisture and dirt. A suitable method of packaging is required for transporting to avoid damage of coating and any external parts of the actuator. Remove the handwheel for transportation.

15. Decommissioning and disposal

- Disconnect the mains supply and ensure that it is secured against an accidental switching-on.
- Open the cover.
- Remove external electrical connections.
- Take off the actuator from the valve.

Disposal

For its disposal, the product should be treated as waste containing electrical and electronic equipment and should not be disposed of as household waste.



In accordance with 2012/19/EU on waste electrical and electronic equipment (WEEE), the devices described here may not be disposed of via municipal waste disposal companies. If you are unable or unwilling to arrange for the equipment to be disposed of by a specialist company, you may return the equipment to the manufacturer, who will then ensure that the equipment is disposed of properly for a flat fee.

16. Appendix

16.1 Accessories

Various accessories are available in order to adapt the actuator to the various installation conditions. The following shows a short selection.

Please see the actuator data sheets for technical data. Operating and installation instructions are available separately for each accessory. We will be pleased to assist you with advice also by telephone.

Accessories/ options	Power supply	230 VAC 1~	115 VAC 1~	24 VAC 1~	400 V 3~	24 VDC
	Position signal switches 2WE	•	•	•	•	•
	Position signal switches gold 2WE Gold	•	•	•	•	•
	Add'l torque switches 2DE	•	•	•	•	•
	Add'l torque switches gold 2DE Gold	•	•	•	•	•
	Positioner PSAP	•	•) ¹	•) ¹	•) ²	
	Position transmitter PSPT	•	•	•	•	•
	Heating resistor HR	•	•	•	•) ³	•
	Potentiometer PD	•	•	•	•	•
	Reversing starter contactor WSM01				•	
	Corrosion protection K2	Corrosion protection K2 incl. heating resistor				
	Enclosure IP67 IP	IP68 incl. heating resistor and corrosion protection K2				

• = available

)¹ = PSAP with external relay required

)² = only to be used with reversing starter contactor

)³ = supply voltage 24 V or 115-230 V



For additional position and torque switches:

Standard switches with silver contacts are suitable for currents 100 mA to 5 A at voltages in the range of 24 V to 230 V AC/DC. For lower power up to 0,12 VA (0,1 mA to 100 mA at 1 V to 24 V AC/DC) we recommend switches with gold contacts (2WE Gold and 2DE Gold).

16.2 EC Declaration of Conformity

Declaration of Incorporation of Part Completed Machinery and EC Declaration of Conformity in compliance with the Directives on EMC and Low Voltage

We,

**PS Automation GmbH
Philipp-Krämer-Ring 13
D-67098 Bad Dürkheim**

Declare under our sole responsibility that we manufacture electric actuator series

**PSR-E...; PSQx03...; PSQ-E...; PSQ-AMS...; PSL-Mod.4...;
PSL-AMS...; PSF...; PSF-M...; PSF-Q...; PSF-Q-M...**

according the requirements of the

EC Directive 2006/42/EC

as part completed machinery. These actuators are designed to be installed on industrial valves.
It is prohibited to take the actuator into service until it has been ensured that the complete machine conforms
the applicable machinery directives.

The technical documentation described in Annex VII, part B has been prepared.

The above actuators further comply with the requirements of the following directives.

2014/30/EU	Electromagnetic Compatibility (EMC)
2014/35/EU	Low Voltage (LVD)
2011/65/EU + 2015/863/EU	Restriction of Hazardous Substances (RoHS)

furthermore, the following harmonised standards have been applied:

EN 61000-6-2: 2005	Electromagnetic compatibility (EMC), Generic standards- Immunity for industrial environments
EN 61000-6-3: 2007	Electromagnetic compatibility (EMC), Generic standards- Emission standard for residential, commercial and light-industrial environments
EN 61010-1: 2020	Safety Requirements for Electrical Equipment for Measurement, Control and Laboratory use

Bad Dürkheim, 2022



Christian Schmidhuber
(General Manager)

CAUTION!

To ensure compliance of these actuators with the above directives, it is the responsibility of the specifier, purchaser, installer and user to observe the relevant specifications and limitations when taking the product into service. Details are available on request, and are mentioned in the Installation and Maintenance Instructions.

16.3 CA Declaration of Conformity

Declaration of Incorporation of Part Completed Machinery and CA Declaration of Conformity in compliance with the Legislation on EMC and Low Voltage

We,

**PS Automation GmbH
Philipp-Krämer-Ring 13
D-67098 Bad Dürkheim**

Declare under our sole responsibility that we manufacture electric actuator series

PSR-E...; PSQx03...; PSQ-E...; PSQ-AMS...; PSL-Mod.4...; PSL-AMS...; PSF...; PSF-M...

according to the requirements of the

2008 No. 1597

Supply of machinery (safety) regulations

as part completed machinery. These actuators are designed to be installed on industrial valves.

It is prohibited to take the actuator into service until it has been ensured that the complete machine conforms to the applicable machinery legislation.

The technical documentation described in Annex VII, part B has been prepared.

The above actuators further comply with the requirements of the following legislations:

**UK SI 2016 No. 1091 and
Amendments**

The Electromagnetic Compatibility Regulations 2016

**UK SI 2016 No. 1101 and
Amendments**

The Electrical Equipment (Safety) Regulations 2016

**UK SI 2012 No. 3032 and
Amendments**

**The Restriction of the Use of Certain Hazardous Substances in
Electrical and Electronic Equipment Regulations 2012**

the provisions of the legislations and their compliance are given by the following named standard(s), which have been applied:

EN 61000-6-2: 2005

Electromagnetic compatibility (EMC), Generic standards-
Immunity for industrial environments

EN 61000-6-3: 2007

Electromagnetic compatibility (EMC), Generic standards-
Emission standard for residential, commercial
and light-industrial environments

EN 61010-1: 2020

Safety Requirements for Electrical Equipment for
Measurement, Control and Laboratory use

Bad Dürkheim, 2021



Christian Schmidhuber
(General Manager)

CAUTION!

To ensure compliance of these actuators with the above directives, it is the responsibility of the specifier, purchaser, installer and user to observe the relevant specifications and limitations when taking the product into service. Details are available on request, and are mentioned in the Installation and Maintenance Instructions.

Our representatives:

Italy

PS Automazione S.r.l.
Via Pennella, 94
I-38057 Pergine Valsugana (TN)
Tel.: <+39> 04 61-53 43 67
Fax: <+39> 04 61-50 48 62
E-mail: info@ps-automazione.it

India

PS Automation India Pvt. Ltd.
Srv. No. 25/1, Narhe Industrial Area,
A.P. Narhegaon, Tal. Haveli, Dist.
IND-411041 Pune
Tel.: <+ 91> 20 25 47 39 66
Fax : <+ 91> 20 25 47 39 66
E-mail : sales@ps-automation.in
www.ps-automation.in

To find out more about all our sales partners and subsidiaries please scan the QR code below or visit our website:

<https://www.ps-automation.com/locations/?lang=en>



PS Automation GmbH

Philipp-Krämer-Ring 13
D-67098 Bad Dürkheim

Phone: +49 (0) 6322 94980-0
E-mail: info@ps-automation.com
www.ps-automation.com

