

Operating Instructions

Local Control Unit PSC.3 for PS-AMS PSQ-S

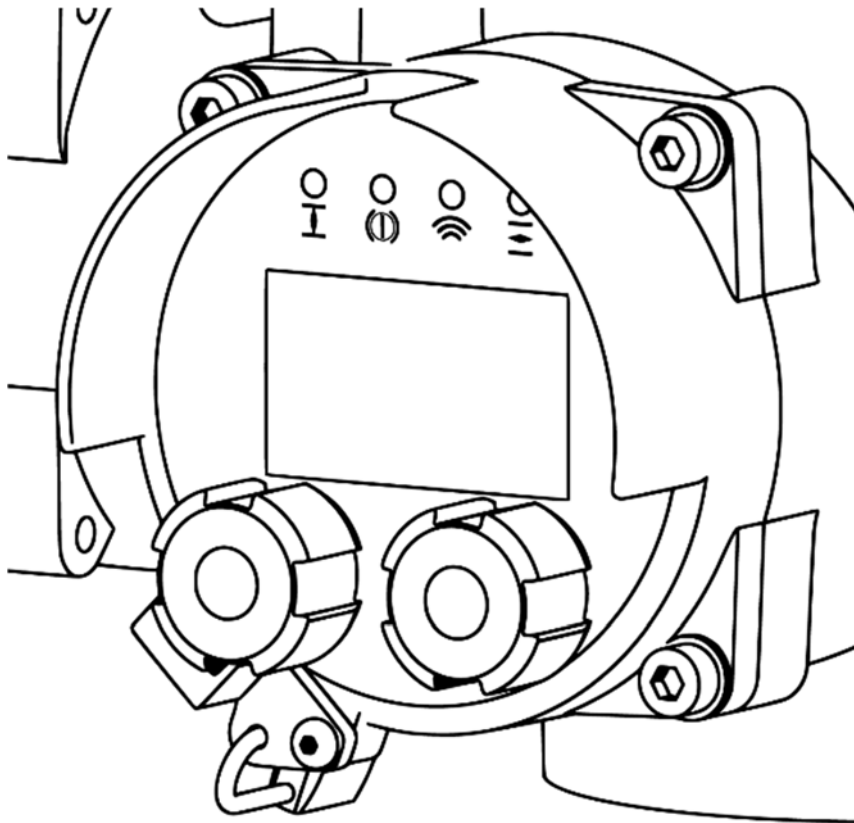

Subject to changes!

Table of Content

1. Symbols and safety	5
2. Mounting and electrical connection	6
3. PSC.3 local control panel.....	7
3.1 Graphic display.....	7
3.2 LED message display	7
3.3 Lockable selector knob	7
3.3.1 Automatic mode	7
3.3.2 Manual (local) mode	8
3.3.3 Off mode	8
3.3.4 Parametrisation mode	8
3.4 Entry knob with push function.....	8
3.5 Diagnosis	8
3.5.1 Display at Local Control PSC.3.....	8
3.5.2 Read out with PSCS.WiFi	8
3.5.3 Read out with communication software PSCS.2.....	8
3.6 Parameters menu.....	9
3.6.1 Set value A [P.1]	9
3.6.1.1 Current [P.1.1].....	9
3.6.1.2 Voltage [P.1.2].....	9
3.6.1.3 OPEN/STOP/CLOSE [P.1.3]	10
3.6.1.4 OPEN/CLOSE [P.1.4]	10
3.6.1.5 Pulse Width Modulation [P.1.5].....	10
3.6.1.6 Fieldbus (in conjunction with optional fieldbus interface) [P.1.6].....	11
3.6.1.7 Fixed value [P.1.7]	11
3.6.1.8 Dead band [P.1.8].....	11
3.6.1.9 Averaging [P.1.9].....	11
3.6.2 Set value B [P.2]	11
3.6.2.1 Current [P.2.1].....	11
3.6.2.2 Voltage [P.2.2].....	12
3.6.2.3 Fieldbus (in conjunction with optional fieldbus interface) [P.2.3].....	12
3.6.2.4 Fixed value [P.2.4]	12
3.6.2.5 Dead band [P.2.5].....	13
3.6.2.6 Averaging [P.2.6]	13
3.6.2.7 Process controller [P.2.7]	13
3.6.2.8 Rotational speed regulator [P.2.8].....	13
Off [P.2.9]	13
3.6.3 Actual value [P.3]	14
3.6.3.1 Current [P.3.1].....	14
3.6.3.2 Voltage [P.3.2].....	14
Source [P.3.3]	14
3.6.4 Binary input [P.4]	14
3.6.4.1 Binary input BA [P.4.1]	15
3.6.4.2 Binary input BB [P.4.2]	15
3.6.4.3 Binary input BC [P.4.3]	15
3.6.5 Valve adaptation [P.5].....	15
3.6.5.1 Closing direction [P.5.1]	15
3.6.5.2 Cut-off valve OPEN [P.5.2]	15
3.6.5.3 Cut-off valve CLOSED [P.5.3]	15
3.6.5.4 Angle [P.5.4]	15
3.6.5.5 Torque [P.5.5]	16
3.6.5.6 Starting torque [P.5.6].....	16

3.6.5.7 Starting time [P.5.7]	16
3.6.5.8 Shut-Off valve OPEN [P.5.8]	16
3.6.5.9 Draw-in valve CLOSE [P.5.9]	16
3.6.5.10 Limit valve OPEN [P.5.10]	16
3.6.5.11 Limit valve CLOSE [P.5.11]	16
3.6.5.12 Rotational speed [P.5.12]	17
3.6.5.13 Emergency operation speed [P.5.13]	17
3.6.5.14 Torque evaluation [P.5.14]	17
3.6.6 Valve characteristic curve [P.6]	17
3.6.7 Rotational speed characteristic curve [P.7]	17
3.6.8 Intermediate positions [P.8]	17
3.6.8.1 Position 1 [P.8.1]	17
3.6.8.2 Position 2 [P.8.2]	17
3.6.8.3 Position 3 [P.8.3]	18
3.6.8.4 Position 4 [P.8.4]	18
3.6.8.5 Position 5 [P.8.5]	18
3.6.9 Commissioning [P.9]	18
3.6.9.1 Automatic [P.9.1]	18
3.6.9.2 Manual [P.9.2]	18
3.6.10 Safety functions [P.10]	18
3.6.10.1 Set value error A [P.10.1]	18
3.6.10.2 Set value error B [P.10.2]	19
3.6.10.3 Torque error [P.10.3]	19
3.6.10.4 Over-temperature [P.10.4]	19
3.6.10.5 Mains power failure [P.10.5]	19
3.6.11 Signalling relays [P.11]	19
3.6.11.1 Relay 1 [P.11.1]	19
3.6.11.2 Relay 2 [P.11.2]	20
3.6.11.3 Relay 3 [P.11.3]	20
3.6.11.4 Relay 4 [P.11.4]	20
3.6.11.5 Relay 5 [P.11.5]	20
3.6.12 Diagnostics [P.12]	20
3.6.12.1 Logging time [P.12.1]	21
3.6.13 Language [P.13]	21
3.6.14 Electronic type-plate [P.14]	21
3.6.15 Clock [P.15]	21
3.6.15.1 Date [P.15.1]	21
3.6.15.2 Time [P.15.2]	21
3.6.16 LCD display [P.16]	21
3.6.16.1 Display [P.16.1]	21
3.6.16.2 Source [P.16.2]	22
3.6.17 Password [P.17]	22
3.6.17.1 Enter [P.17.1]	22
3.6.17.2 Change [P.17.2]	22
3.6.17.3 Reset [P.17.3]	22
3.6.18 Wi-Fi [P.18]	22
3.6.18.1 Settings [P.18.1]	22
3.6.19 Fieldbus [P.19]	23
3.6.19.1 PROFIBUS [P.19.1]	23

1. Symbols and safety

General dangers of non-compliance with safety regulations

PS-AMS PSQ actuators are built at state-of the art technology and are safe to operate. Despite of this, the actuators may be hazardous if operated by personnel that has not been sufficiently trained or at least instructed, and if the actuators are handled improperly, or not used as per specification.

This may

- cause danger to life and limb of the user or a third party,
- damage the actuator and other property belonging to the owner,
- reduce safety and function of the actuator.

To prevent such problems, please ensure that these operating instructions and the safety regulations in particular have been read and understood by all personnel involved in the installation, commissioning, operation, maintenance and repair of the actuators.

Basic safety notes

- The actuators may only be operated by skilled and authorized operating personnel.
- Make sure to follow all security advices mentioned in this manual, any national rules for accident prevention, as well as the owner's instructions for work, operation and safety.
- The isolating procedures specified in these Operating Instructions must be followed for all work pertaining to the installation, commissioning, operation, change of operating conditions and modes, maintenance, inspection, repair and installation of accessories
- Before opening the actuator cover, ensure that mains supply is isolated and prevented from unintended re-connection.
- Areas that can be under voltage have to be isolated before working on them.
- Ensure that the actuators are always operated in faultless condition. Any damage or faults, and changes in the operational characteristics that may affect safety, must be reported at once.

Danger signs

The following danger signs are used in this operating manual:



Caution! There is a general risk of damage related to health and/or properties.



Danger! Electrical voltages are present that may lead to death. Life threatening risks may occur due to electrical voltages! Avoid personal or material damages by observing applicable regulations and safety standards!



Danger! This sign warns of hazards posing a risk to health. Ignoring these instructions can lead to injuries.



Attention! Observe precautions for handling. Electrostatic sensitive devices.

Other notes

- The motor surface temperature may rise when maintaining, inspecting and repairing the actuator immediately after the operation. There is a danger of burning the skin!
- Always consult the relevant operating instructions when mounting PS accessories or operating the actuator with PS accessories.
- Connections for signal in- and output are double isolated from circuits that can be under dangerous voltage.

2. Mounting and electrical connection

Disconnect the actuator from the supply voltage. Wait until the PSCP (if installed) has fully discharged. Remove the cover which is next to the hand wheel from the actuator housing. Insert the connection plug for the local control unit into the control board.

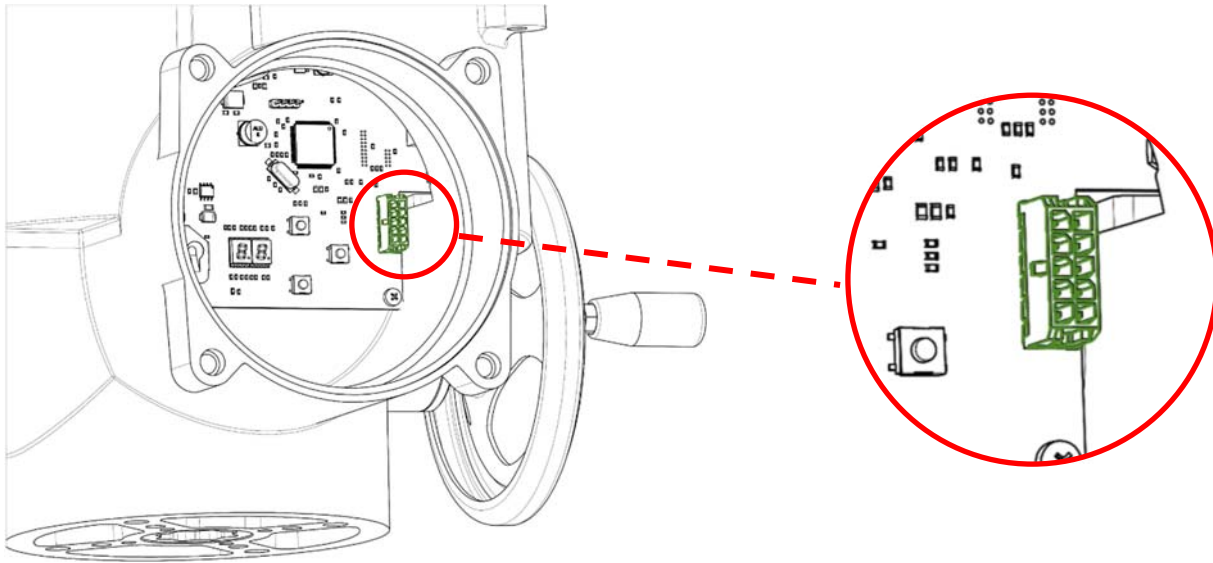

Figure 1: Connecting PSC.3 on the control board

Align and fasten the local control unit in place.

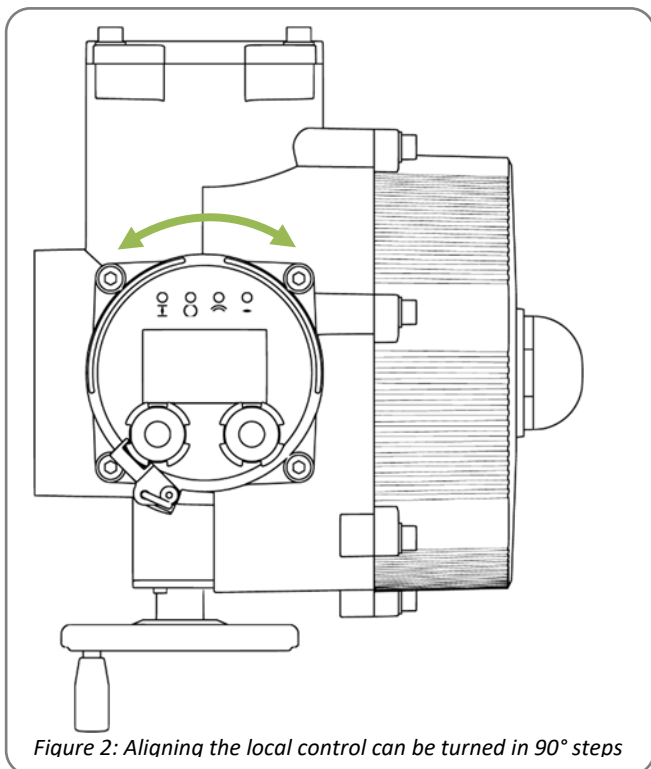

Figure 2: Aligning the local control can be turned in 90° steps

The local control unit is designed to be mounted in 90° steps to suit the installation position of the actuator.

Maximum angle is +/-180°

3. PSC.3 local control panel

The local control panel provides a display of the actuator position as well as indication of the actuator status using LEDs and plain text.

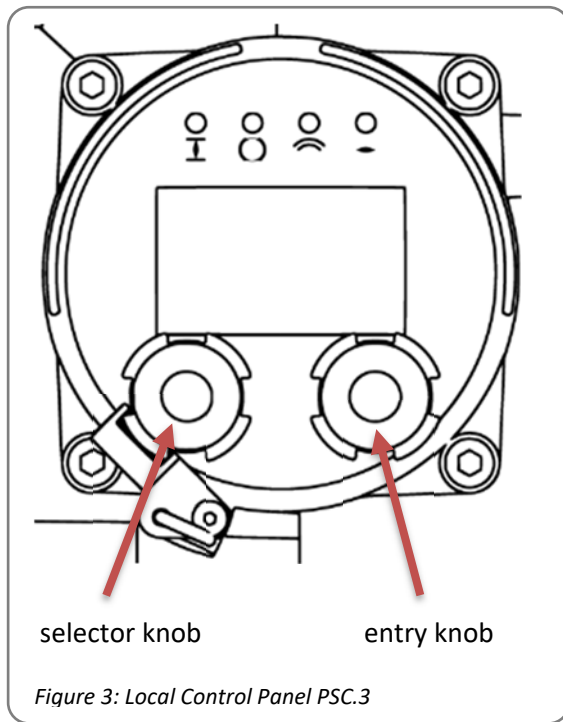

It consists of a multicolour, backlit graphic display, 4 LEDs as well as a selector knob, and an entry knob with push function.

3.1 Graphic display

- Position indicator in 0-100 % / 0-90°
- Bar display for motor current / torque 0-100%
- Symbols for valve OPEN/CLOSED
- Two-line text display for message text
- Status code display
- Parameters menu
- Diagnostics monitor (see 8.6)

3.2 LED message display

- Yellow: Valve closed
- Green: Valve open
- Red: Collective error
- Blue:
 - On: Wi-Fi connection active
 - Flashing: Wi-Fi ready, no connection
 - Off: Wi-Fi off

3.3 Lockable selector knob

The rotary selector knob is used to select one of four operating modes. Its position is absolutely encoded so that it keeps the mode when the actuator is switched off.

The selector knob can be locked with a padlock.

3.3.1 Automatic mode

Operating mode with control by process control signals.

3.3.2 Manual (local) mode

Local operation of the actuator. The actuator can be driven between the stored valve end positions with the entry knob on the right side.

If the entry knob is pressed and turned at the same time, the actuator runs continuously in the respective direction. The movement can be stopped with a brief press of the entry knob.

3.3.3 Off mode

The actuator is in off mode and does not react to signals from the process control

3.3.4 Parametrisation mode

Parameters menu for adjusting the actuator-specific parameters. (3.6 Parameters menu)

3.4 Entry knob with push function

The entry knob can be used to navigate in the menu or to change the actuator position during manual local operation or commissioning. The entry knob must be pressed (push function) to confirm an entry.

3.5 Diagnosis

3.5.1 Display at Local Control PSC.3

Local control PSC.3 allows to display the data as per the screens below, with the selector switch in position 'Automatic' or 'Off'.

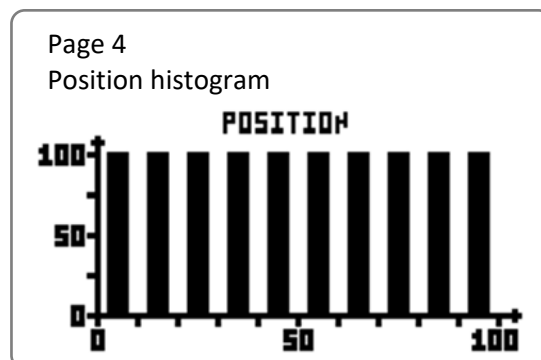
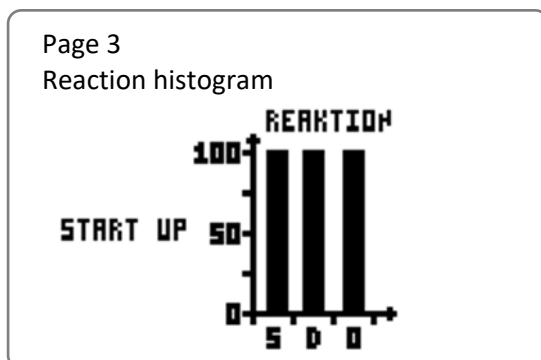
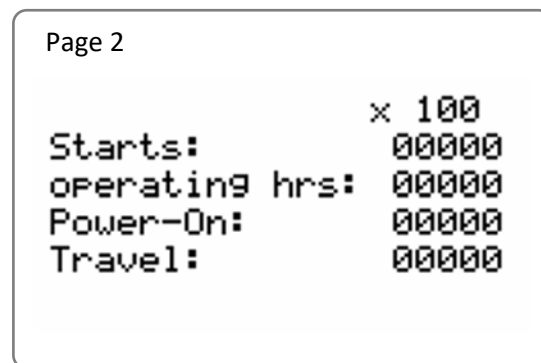
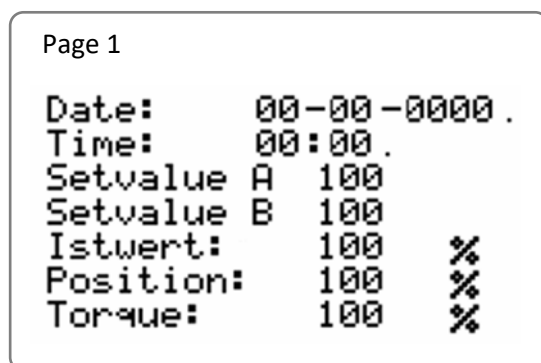

3.5.2 Read out with PSCS.WiFi

Using the actuator's Wi-Fi option, the Event logging and the Daily logging can be displayed on a mobile device.

3.5.3 Read out with communication software PSCS.2

Parameters and diagnostics logging data can be loaded from the actuator with the PSCS.2 PC software and the AMS.2 USB cable and saved locally for further assessment.

3.6 Parameters menu

The entry knob can be used to scroll in the menu. It must be pressed (pushed) to switch to a sub-menu. Numeric selections are likewise confirmed with a press of the input switch. Functions must be selected by selecting "Activate?", which can be found in the respective sub-menu. The current selection is marked with a tick.

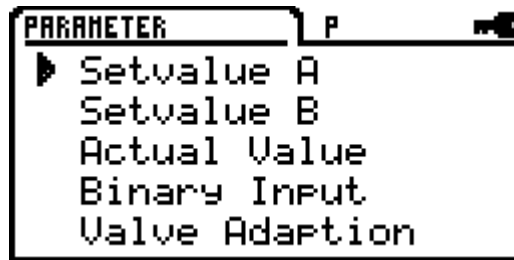

Each menu has a unique number, which is displayed in the top right of the display [P.x.x.x]. This can be used to determine which menu level you are currently in.

3.6.1 Set value A [P.1]

Selection of the set value for position regulation by an external controller.

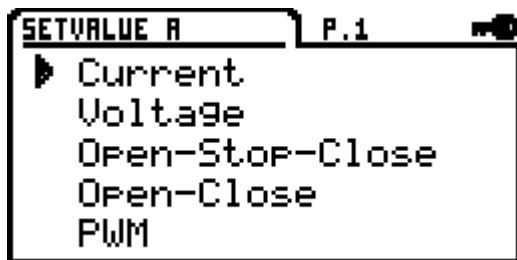

3.6.1.1 Current [P.1.1]

Current selects the set value as analogue current signal in the range 0 mA to 20 mA

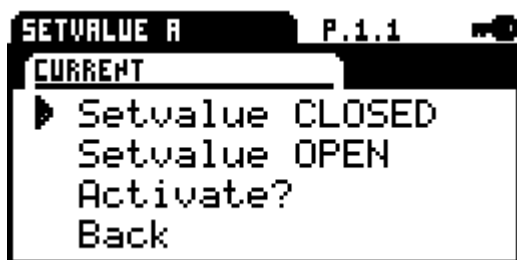

Set value CLOSE [P.1.1.1]

Set value for valve CLOSED

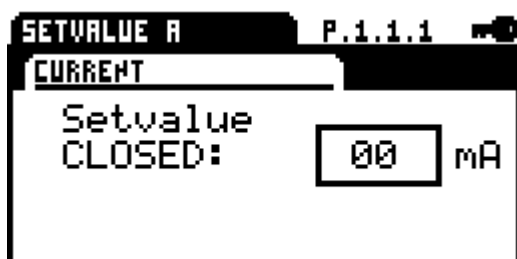

Set value OPEN [P.1.1.2]

Set value for valve OPEN



Activate?

When confirmed, the set value is activated.

3.6.1.2 Voltage [P.1.2]

Voltage selects the set value as analogue voltage signal in the range 0 V to 10 V.

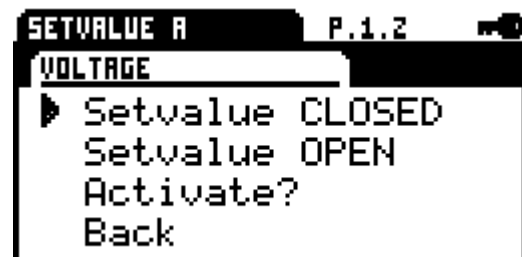

Set value CLOSE [P.1.2.1]

Set value for valve CLOSED



Set value OPEN [P.1.2.2]
Set value for valve OPEN



Activate?
When confirmed, the set value is activated

3.6.1.3 OPEN/STOP/CLOSE [P.1.3]

Actuator follows the binary inputs BA to BC. It runs in the respective direction OPEN/CLOSE if a rising signal edge is detected. The actuator stops if the Stop signal is set or if the end position is reached.

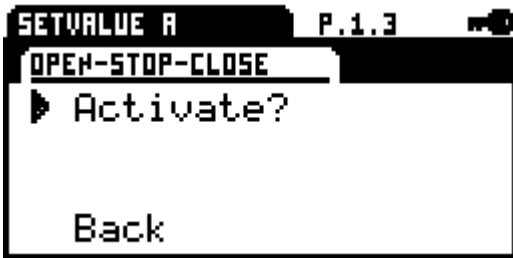

The assignment of the functions of the binary inputs is stipulated in the binary inputs menu 3.6.4.

Activate?
When confirmed, actuator mode is activated.

3.6.1.4 OPEN/CLOSE [P.1.4]

Actuator mode by means of binary inputs BA-BC. In actuator mode the actuator runs so long as a binary signal is present. The actuator stops automatically when the signal is no longer present.

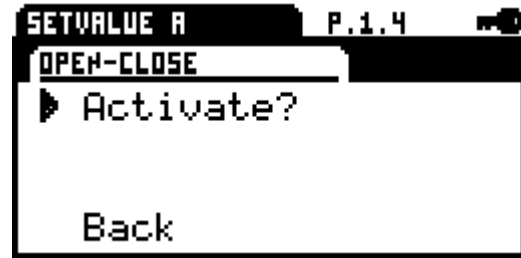

The assignment of the functions of the binary inputs is stipulated in the binary inputs menu.

Activate?
When confirmed, actuator mode is activated.

3.6.1.5 Pulse Width Modulation [P.1.5]

To use a PWM signal as set value, the binary input BA must be parametrised as PWM (see 3.6.4.1 Binary input BA [P.4.1]).

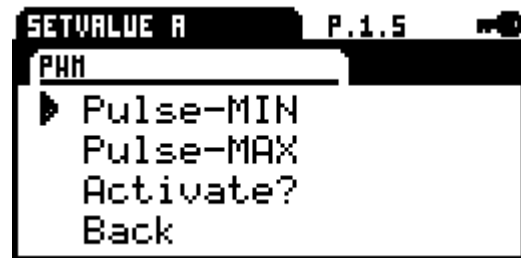

Pulse MIN [P.1.5.1]
Minimum pulse length 5-20 % from PWM



Pulse MAX [P.1.5.2]
Maximum pulse length 80-95 % from PWM



Activate?
When confirmed, PWM is activated

3.6.1.6 Fieldbus (in conjunction with optional fieldbus interface) [P.1.6]

Set value via the fieldbus interface in the range 0-1000 %

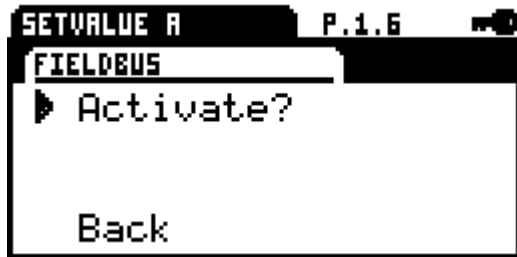

Activate?

When confirmed, the digital set value is activated for a fieldbus interface.

3.6.1.7 Fixed value [P.1.7]

Fixed value, e.g. for use in conjunction with the optional process controller PSIC, in the range 0-1000 % of the valve travel that was stored after commissioning.



Value [P.1.7.1]

Enter fixed set value



Activate?

When confirmed, a fixed value is activated as set value.

3.6.1.8 Dead band [P.1.8]

Adjustable in the range of 5-100 % of the maximum set value.

Value [P.1.8.1]

Dead band setting



3.6.1.9 Averaging [P.1.9]

Averaging of the set value in the range of 1 to 64 times.

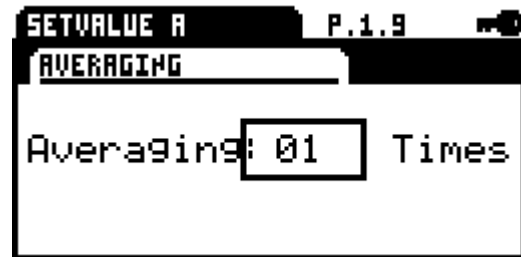

3.6.2 Set value B [P.2]

Selection of set value B, which can be used for optional functions.

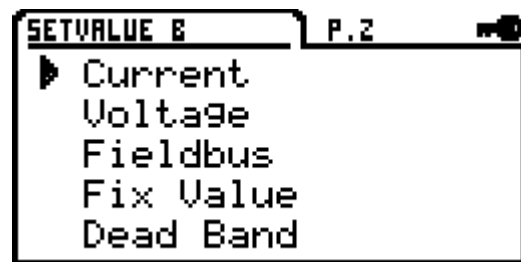

3.6.2.1 Current [P.2.1]

The set value for the current can be selected in a range of 0 mA to 20 mA

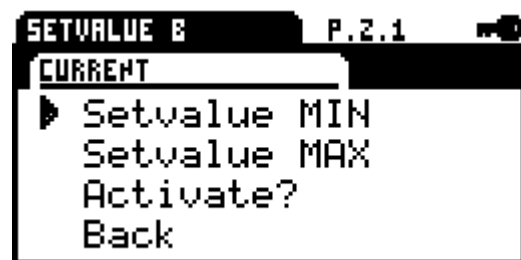

Set value MIN [P.2.1.1]

Minimum set value stipulation for optional function

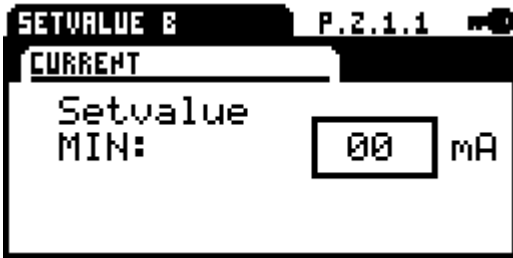

Set value MAX [P.2.1.2]

Maximum set value stipulation for optional function



Activate?

When confirmed, the set value is activated.

3.6.2.2 Voltage [P.2.2]

The set value for the voltage can be selected in a range of 0 V to 10 V.

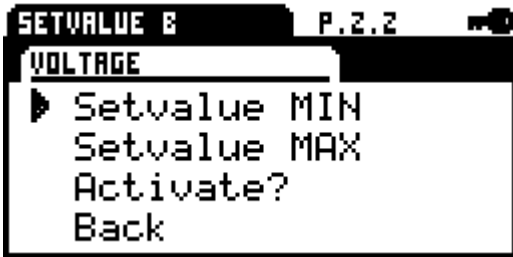

Set value MIN [P.2.2.1]

Minimum set value stipulation for optional function

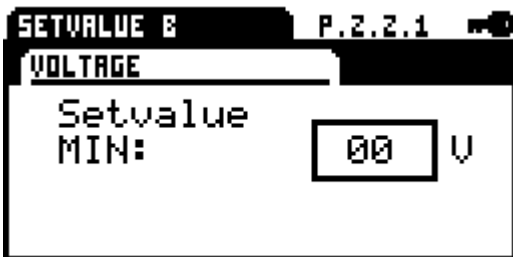

Set value MAX [P.2.2.2]

Maximum set value stipulation for optional function

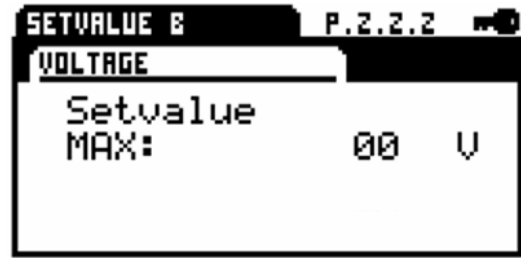

Activate?

When confirmed, the set value is activated.

3.6.2.3 Fieldbus (in conjunction with optional fieldbus interface) [P.2.3]

Set value via the fieldbus interface in the range 0-1000‰.

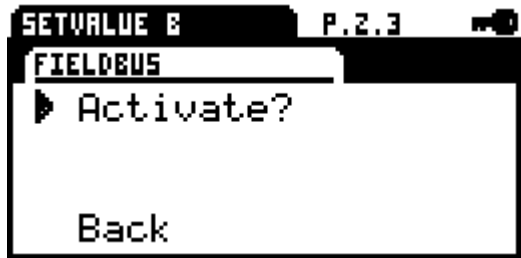

Activate?

When confirmed, the digital set value is activated for a fieldbus interface.

3.6.2.4 Fixed value [P.2.4]

Fixed value as set value stipulation in the range 0-1000‰.

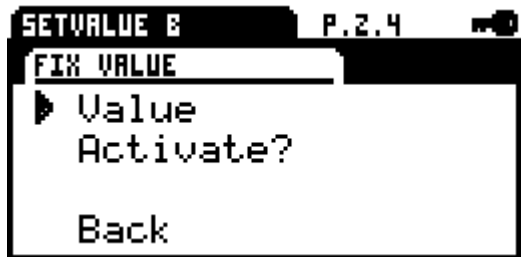

Value [P.2.4.1]

Enter fixed value



Activate?

When confirmed, a fixed value is activated as set value.

3.6.2.5 Dead band [P.2.5]

Adjustable in the range of 5-100% of the maximum set value.

Value [P.2.5.1]

Dead band setting

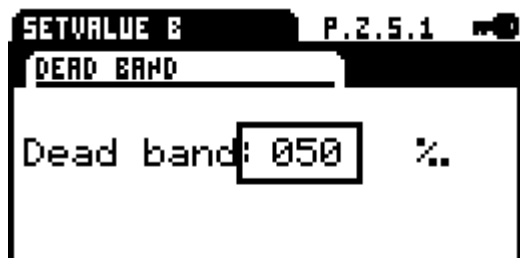

3.6.2.6 Averaging [P.2.6]

Averaging of the set value in the range of 1 to 64 times.

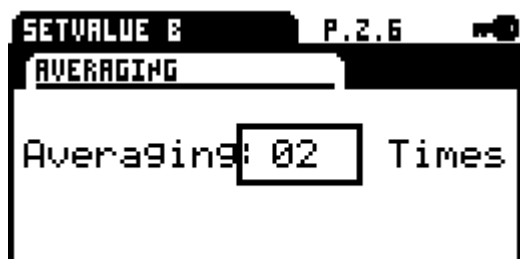

3.6.2.7 Process controller [P.2.7]

Setting the optional integrated process controller PSIC

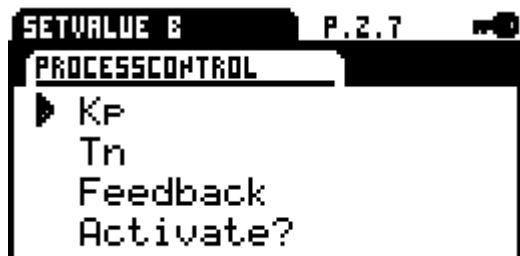

Kp [P.2.7.1]

Amplification factor



Tn [P.2.7.2]

Delay time

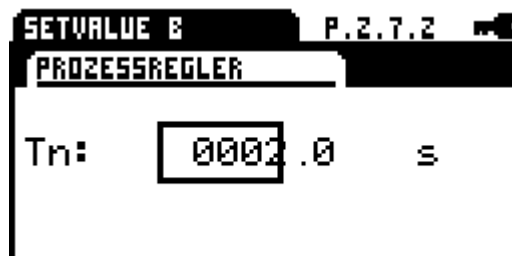

Operating direction [P.2.7.3]

Operating direction of the process sensor:
positive = direct
negative = reverse

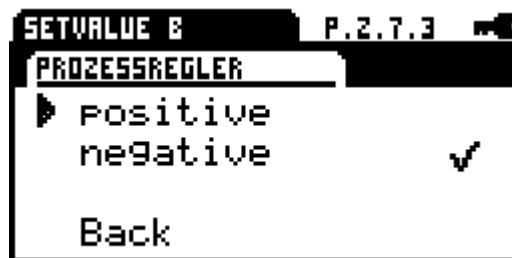

3.6.2.8 Rotational speed regulator [P.2.8]

Activation of the integrated speed regulator via set value B, enabling the actuator speed to be continuously adjusted between minimum speed 25% and maximal 100%.

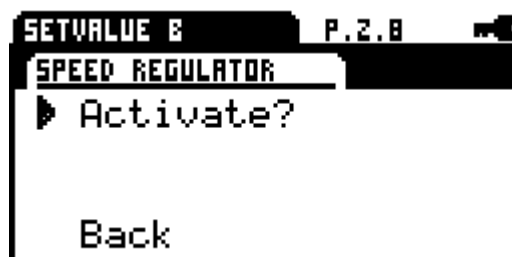

When the speed regulator via set value B is activated, the speed characteristic curve will be deactivated.

In case of fail safe operation, the parameterised speed will be used.

When speed regulator is activated and set value B is missing, the actuator will run with its minimum rotational speed.

Off [P.2.9]

Set value B switched off (standard setting)

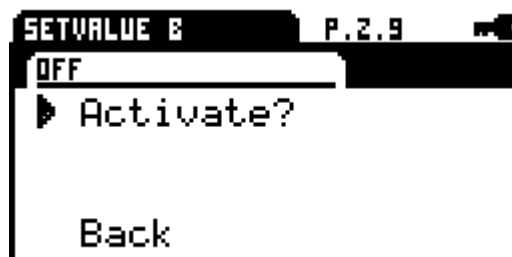

3.6.3 Actual value [P.3]

Active feedback signal (see [P.3.3] below)

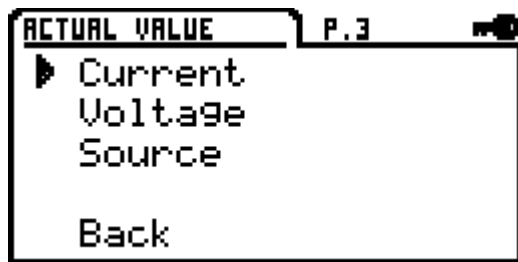

3.6.3.1 Current [P.3.1]

The signal range is adjustable between 0 mA and 20 mA

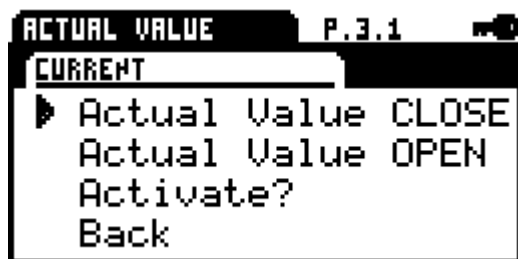

Actual value CLOSE [P.3.1.1]

Feedback signal for closed valve.

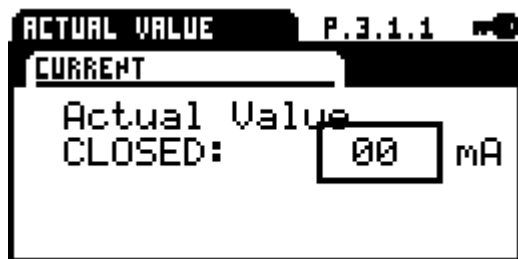

Actual value OPEN [P.3.1.2]

Feedback signal for open valve.

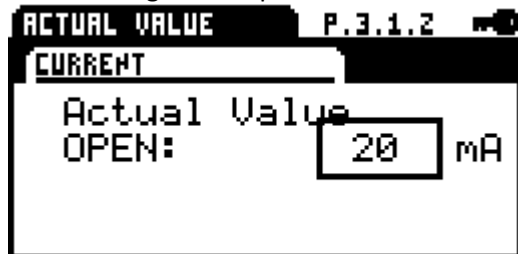

Activate?

When confirmed, the feedback signal is activated.

3.6.3.2 Voltage [P.3.2]

The signal range is adjustable between 0 V and 10 V

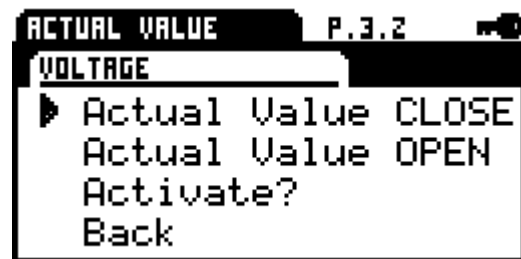

Actual value CLOSE [P.3.2.1]

Feedback signal for closed valve.

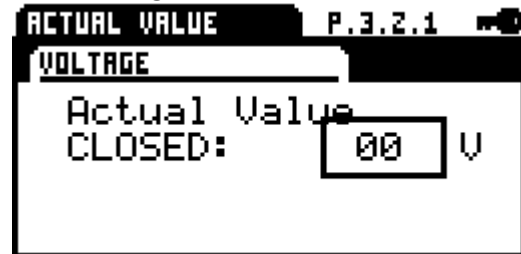

Actual value OPEN [P.3.2.2]

Feedback signal for open valve.

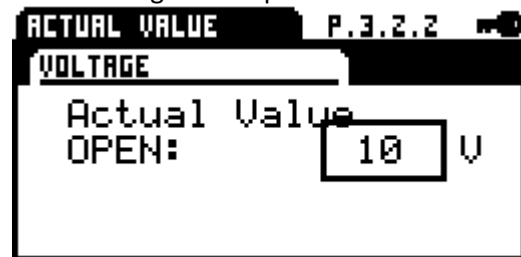

Activate?

When confirmed, the feedback signal is activated.

Source [P.3.3]

Selection of the source for the feedback signal.

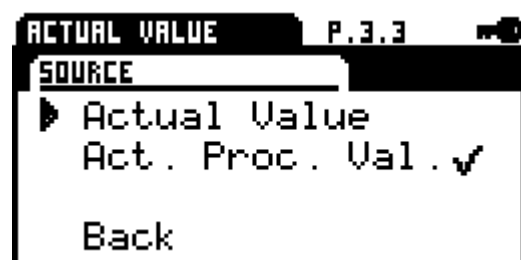

Actual value

Signalling of actuator position (standard)

Actual process value

Feedback from the process sensor (with option PSIC), equals input signal for set value B)

3.6.4 Binary input [P.4]

The actuator has galvanically isolated binary multi-voltage input ports, BA/BB have a common neutral

line connection COM. BC is galvanically isolated from BA/BB.

If a voltage is present at a binary input port, the actuator drives to the parametrised position regardless of the analogue or digital set value applied.

The prioritisation is implemented from BA (highest priority) to BC (lowest priority). Exception when parametrising BA PWM

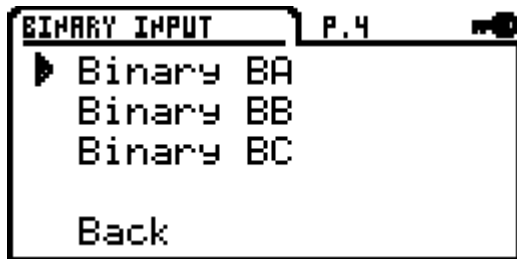

3.6.4.1 Binary input BA [P.4.1]

- No function
- OPEN
- CLOSE
- Stop
- PWM (in conjunction with set value A PWM)
- Position 1
- Position 2
- Position 3
- Position 4
- Position 5

3.6.4.2 Binary input BB [P.4.2]

- No function
- OPEN
- CLOSE
- Stop
- Position 1
- Position 2
- Position 3
- Position 4
- Position 5

3.6.4.3 Binary input BC [P.4.3]

- No function
- OPEN
- CLOSE
- Stop
- Position 1
- Position 2
- Position 3
- Position 4
- Position 5

3.6.5 Valve adaptation [P.5]

Configuring the actuator on the function of the valve.

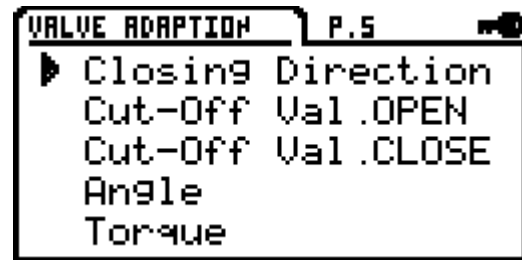

3.6.5.1 Closing direction [P.5.1]

Selection of the closing direction of the actuator



- CCW = counter-clockwise
- CW = clockwise

3.6.5.2 Cut-off valve OPEN [P.5.2]

Cut-off in the open position of the valve



- Position
- Torque

3.6.5.3 Cut-off valve CLOSED [P.5.3]

Cut-off in the closed position of the valve

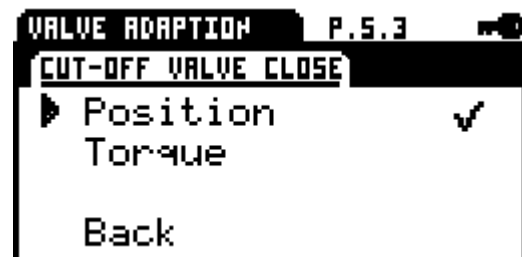

- Position
- Torque

3.6.5.4 Angle [P.5.4]

Valve travel in degrees



Note: For automatic automatic commissioning with two torque dependent end positions, this value is calculated by the actuator.

3.6.5.5 Torque [P.5.5]

The operation torque can be adjusted between 30% and 100% of the actuator's nominal torque.



3.6.5.6 Starting torque [P.5.6]

The starting torque can be adjusted between 30% and 120% of the actuator's nominal torque. The starting torque is only active in case if the starting time is adjusted to more than 0 ms. Please note that the starting torque needs to be adjusted separately from the torque adjustment explained at 3.6.5.5!



3.6.5.7 Starting time [P.5.7]

Duration for which the starting torque is provided. Range is 0 to 2000 ms



3.6.5.8 Shut-Off valve OPEN [P.5.8]

Draw-in range 80-100%, which is used to drive to the end position during a torque shut-off.



3.6.5.9 Draw-in valve CLOSE [P.5.9]

Draw-in range 0-20%, which is used to drive to the end position during a torque shut-off



3.6.5.10 Limit valve OPEN [P.5.10]

End position limiting 80-100%, which will not be exceeded after set-up. The limiting will be switched off if the value is set higher than 100%, indicated in the display as "OFF".



3.6.5.11 Limit valve CLOSE [P.5.11]

End position limiting 0-20%, which will not be exceeded after set-up. The limiting will be switched off if the value is set lower than 0%, indicated in the display as "OFF".



3.6.5.12 Rotational speed [P.5.12]

Global rotational speed limiting as upper limit of the characteristic curve for rotational speed



3.6.5.13 Emergency operation speed [P.5.13]

Rotational speed that will be used during emergency operation independent of the characteristic curve for rotational speed or the rotational speed regulator.



3.6.5.14 Torque evaluation [P.5.14]



Current

Evaluation of the motor current for torque measurement.

Sensor (option)

Evaluation of a sensor for torque measurement

3.6.6 Valve characteristic curve [P.6]

The dependence of the command variable to the valve position/characteristic can be adapted by means of characteristic curves. There are 11 grid points available for this. A linear relationship is set as standard when shipped.

The grid points can be selected by means of the rotary switch. The value can be changed by pressing the rotary switch and then turning it. Pressing again saves the setting permanently.

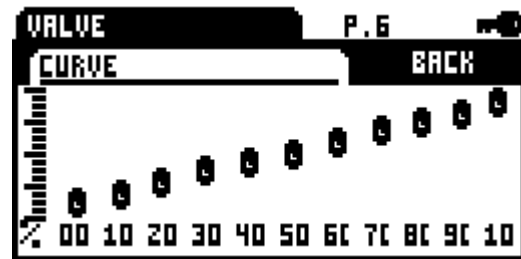

Exit the menu by pressing the BACK button.

3.6.7 Rotational speed characteristic curve [P.7]

The rotational speed of the actuator can be parameterised with 11 grid points between minimum speed and the global rotational speed limit, enabling individual settings to be implemented for gentle valve actuation. A straight-line relationship to the global rotational speed limit is set as standard 3.6.5.12

The grid points can be selected by means of the rotary switch. The value can be changed by pressing the rotary switch and then turning it. Pressing again saves the setting permanently.

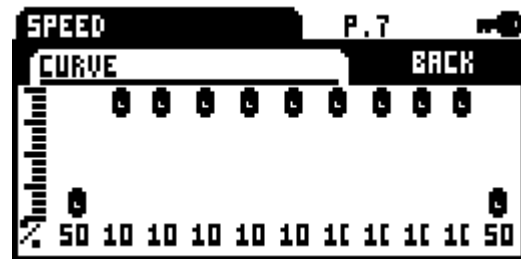

Exit the menu by pressing the BACK button.

3.6.8 Intermediate positions [P.8]

The intermediate positions set can be selected with the safety functions or binary inputs and driven to by the actuator.

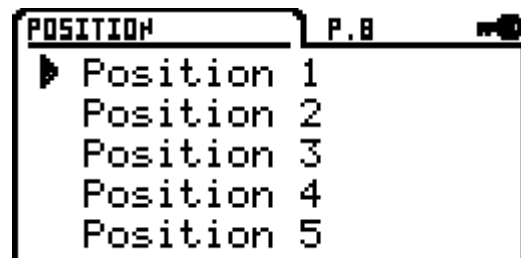

3.6.8.1 Position 1 [P.8.1]

Setting the position in the range 0-100%

3.6.8.2 Position 2 [P.8.2]

Setting the position in the range 0-100%

3.6.8.3 Position 3 [P.8.3]

Setting the position in the range 0-100%

3.6.8.4 Position 4 [P.8.4]

Setting the position in the range 0-100%

3.6.8.5 Position 5 [P.8.5]

Setting the position in the range 0-100%

3.6.9 Commissioning [P.9]

The actuator can automatically determine the valve end positions or they can be set manually depending on the shut-off set.

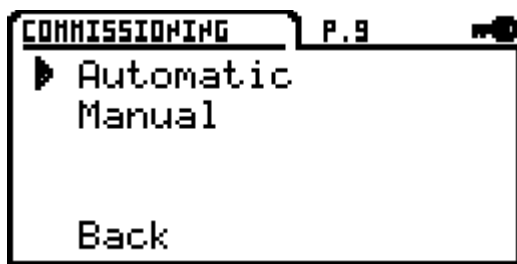

3.6.9.1 Automatic [P.9.1]

If at least one valve end position is set to torque, the valve compensation can be automatically carried out.

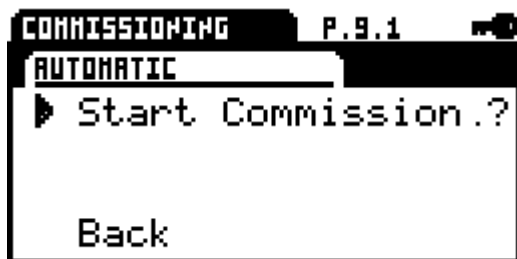

The actuator runs through the stroke of the valve with reduced speed in the parametrised direction valve OPEN and/or valve CLOSE. If a torque is detected, the actuator saves this position.

If both end positions have been parametrised to torque, the actuator determines the intermediate angle autonomously.

If only one end position has been parametrised to torque, the actuator adds the pre-adjusted angle from the recognised torque position. In doing so, the actuator does not check whether the parametrised angle is too large for the remaining range.

Info: The end position calculated on the basis of the pre-adjusted angle, can then be changed by means of the manual set-up 8.4.5.9.2. The angle will then be calculated anew.

Start valve set-up

If the selection is confirmed, the actuator starts to search for a torque end position in the parametrised direction(s).

3.6.9.2 Manual [P.9.2]

If both valve end positions are set to position, the valve set-up must be implemented manually. In doing so, the system can drive to the respective end position with the rotary switch and save it with a long press (3 sec.).

If the rotary switch is pressed before being turned, rapid speed is activated and so a larger range can be covered without having to actuate the rotary switch.

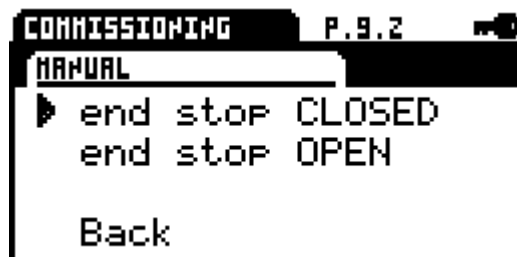

CLOSED end position: Manual selection of the CLOSED position

OPEN end position: Manual selection of the OPEN position

Info: The end position calculated on the basis of the angle during automatic valve compensation, can be adjusted with this setting. The angle will then be calculated anew.

3.6.10 Safety functions [P.10]

With the safety functions, the actuator can be driven to a previously parametrised position in the event of a fault message.

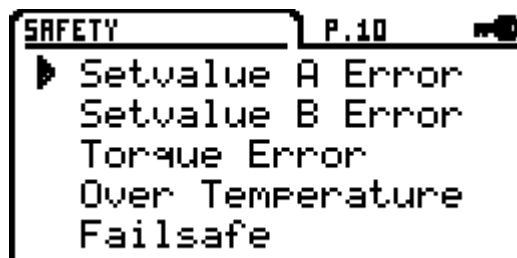

3.6.10.1 Set value error A [P.10.1]

If the analogue set value lies 50% below the value of the minimum set value, one of the following safety functions can be carried out:

- OPEN
- CLOSE
- Stop
- Position 1

- Position 2
- Position 3
- Position 4
- Position 5

Info: The function is deactivated with the selection of a set value range of 0-20 mA or 0-10 V.

3.6.10.2 Set value error B [P.10.2]

If the analogue set value lies 50% below the value of the minimum set value, one of the following safety functions can be carried out:

- OPEN
- CLOSE
- Stop
- Position 1
- Position 2
- Position 3
- Position 4
- Position 5

Info: The function is deactivated with the selection of a set value range of 0-20 mA or 0-10 V

3.6.10.3 Torque error [P.10.3]

If the maximum torque is reached in the direction of an end position outside the draw-in, the following safety functions can be selected:



- Stop
- Retry

With the "Retry" setting, the actuator tries two times with maximum torque to drive past a detected blockage. If this does not work, the actuator stops and reports a torque error.

3.6.10.4 Over-temperature [P.10.4]

If the temperature monitoring system reaches the 70°C warning threshold, the following safety functions can be selected:

- Speed reduction
- OPEN
- CLOSE
- Stop
- Position 1

- Position 2
- Position 3
- Position 4
- Position 5

Info: If "Speed reduction" is selected, the actuator continues to run with the lowest rotational speed possible. If the temperature reaches the 75°C shut-off threshold during continued operation, the actuator stops.

3.6.10.5 Mains power failure [P.10.5]

In the event of a failure of the supply voltage, the following safety functions can be selected:

- OPEN
- CLOSE
- Stop
- Position 1
- Position 2
- Position 3
- Position 4
- Position 5

Attention: The function requires that the PSCP option is installed in the actuator!

3.6.11 Signalling relays [P.11]

5 potential-free signalling relays with NC and NO contacts are available for reporting events. The following events can be assigned to the signalling relays:

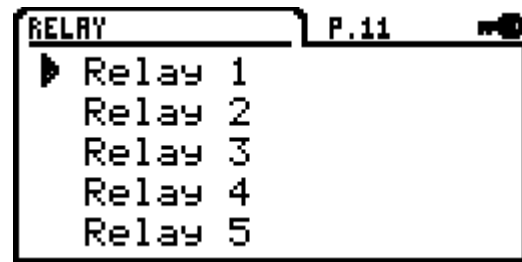

3.6.11.1 Relay 1 [P.11.1]

- Set value error - A
- Set value error - B
- Torque error OPEN
- Torque error CLOSE
- Over temperature
- Low voltage
- Fail safe
- Actuator local (manually integrated / Wi-Fi / manual PSC)
- Actuator Remote
- Actuator OFF
- Collective Error

- End position not reached
- End position passed over
- Position 1
- Position 2
- Position 3
- Position 4
- Position 5

3.6.11.2 Relay 2 [P.11.2]

- Set value error - A
- Set value error - B
- Torque error OPEN
- Torque error CLOSE
- Over temperature
- Low voltage
- Fail safe
- Actuator local (manually integrated / Wi-Fi / manual PSC)
 - Actuator Remote
 - Actuator OFF
 - Collective Error
 - End position not reached
 - End position passed over
 - Position 1
 - Position 2
 - Position 3
 - Position 4
 - Position 5

3.6.11.3 Relay 3 [P.11.3]

- Set value error - A
- Set value error - B
- Torque error OPEN
- Torque error CLOSE
- Over temperature
- Low voltage
- Fail safe
- Actuator local (manually integrated / Wi-Fi / manual PSC)
 - Actuator Remote
 - Actuator OFF
 - Collective Error
 - End position not reached
 - End position passed over
 - Position 1
 - Position 2
 - Position 3
 - Position 4
 - Position 5

3.6.11.4 Relay 4 [P.11.4]

- Set value error - A
- Set value error - B
- Torque error OPEN

- Torque error CLOSE
- Over temperature
- Low voltage
- Fail safe
- Actuator local (manually integrated / Wi-Fi / manual PSC)
 - Actuator Remote
 - Actuator OFF
 - Collective error
 - End position not reached
 - End position passed over
 - Position 1
 - Position 2
 - Position 3
 - Position 4
 - Position 5

3.6.11.5 Relay 5 [P.11.5]

- Set value error - A
- Set value error - B
- Torque error OPEN
- Torque error CLOSE
- Over temperature
- Low voltage
- Fail safe
- Actuator local (manually integrated / Wi-Fi / manual PSC)
 - Actuator Remote
 - Actuator OFF
 - Collective Error
 - End position not reached
 - End position passed over
 - Position 1
 - Position 2
 - Position 3
 - Position 4
 - Position 5

3.6.12 Diagnostics [P.12]

The actuator is equipped with comprehensive diagnostics functionality, whereby the values and messages are saved in the integrated non-volatile (FLASH) memory.

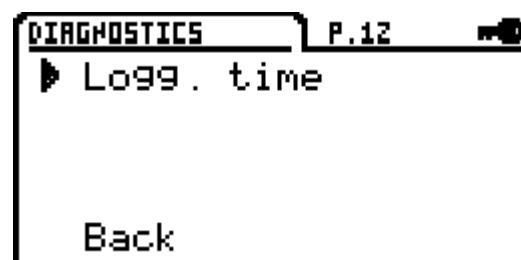

A description of the diagnostic function can be found in the Diagnostics chapter (see Fehler! Verweisquelle konnte nicht gefunden werden.)

3.6.12.1 Logging time [P.12.1]

The recording rate for time logging can be set between 10 and 3600 seconds

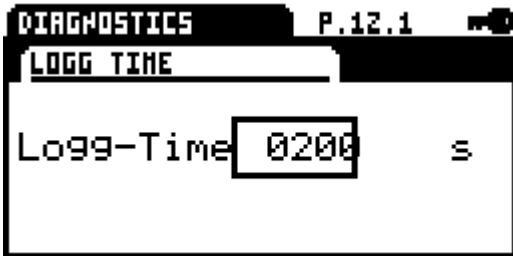

3.6.13 Language [P.13]

Changeover of the menu language for the parameters menus as well as the message text



- Deutsch
- English

3.6.14 Electronic type-plate [P.14]

The electronic type-plate provides specific actuator data.

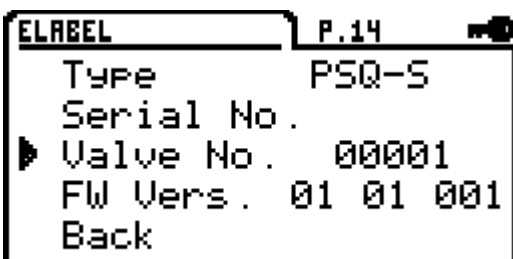

Type: Actuator type

Serial number: Serial number of the actuator

Valve no.: The valve number can be entered by the customer in a numeric form of 0-999999.

FW version: Firmware version of the actuator

3.6.15 Clock [P.15]

Setting menu for the time/date. The clock is used to make accurate recording timestamps when recording messages.

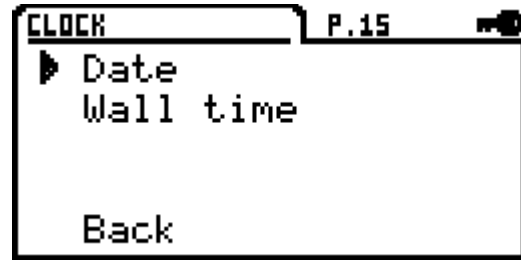

The clock has a battery backup and continues to run in the event of a mains power failure.

3.6.15.1 Date [P.15.1]

Setting of day / month / year

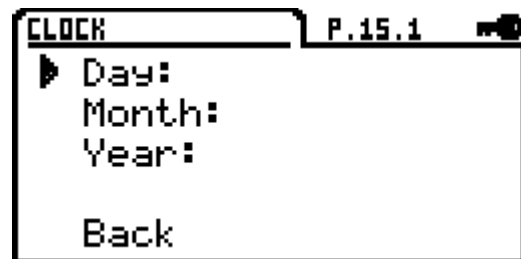

3.6.15.2 Time [P.15.2]

Setting of hours / minutes



3.6.16 LCD display [P.16]



3.6.16.1 Display [P.16.1]

Display of the actuator position in % (percent) or in ° (angle)

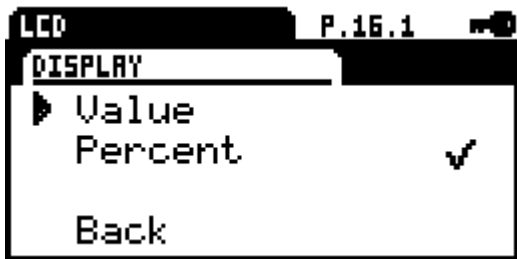

3.6.16.2 Source [P.16.2]

Source of the display is the actuator position / actual value or the actual process value.

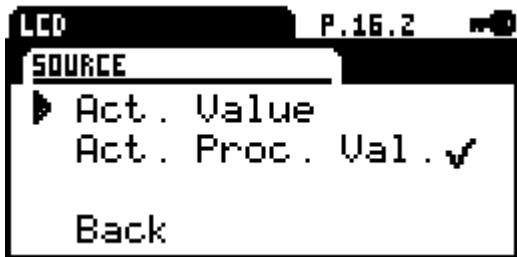

3.6.17 Password [P.17]

The parameters menu can be protected against changes with a password. The password will always be requested when accessing the menu.

Accessing the menu without a valid password enables the parameters to be viewed but not changed. This locking feature is indicated by a key symbol in the top right of the display.

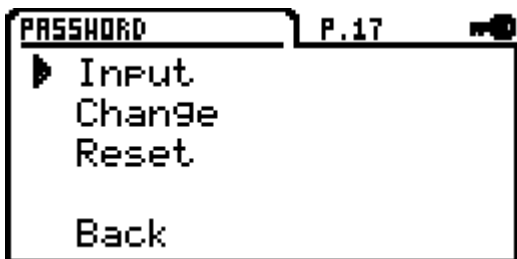

Info: If the password is set to 0000, the protection is deactivated.

3.6.17.1 Enter [P.17.1]

Entry of a valid password. Parameters cannot be changed without the password.



3.6.17.2 Change [P.17.2]

Change password / enter a new password



3.6.17.3 Reset [P.17.3]

If the password is lost, a new password can be requested from PS Automation using the code displayed.

In order to generate a code and delete the current password, "New password" must be confirmed with the push function.

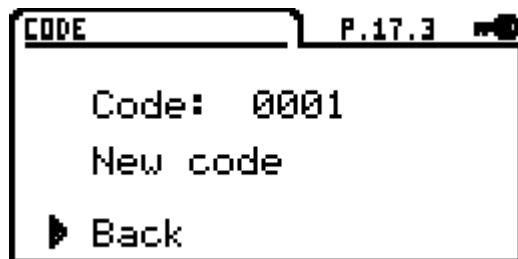

Attention: This function permanently deletes the old password!

Changes can be made once again after entering the new password.

3.6.18 Wi-Fi [P.18]

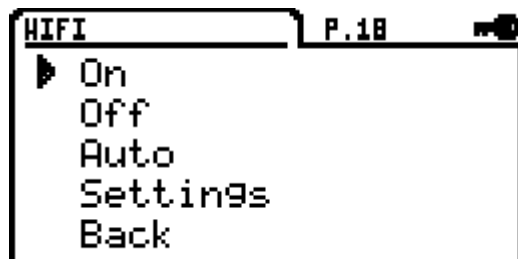

ON: Wi-Fi is switched on permanently

OFF: Wi-Fi is switched off

Auto: Wi-Fi switches OFF automatically if no one is logged on at the actuator or if there is no activity for a defined period of time. This prevents the actuator having a permanent Wi-Fi connection.

3.6.18.1 Settings [P.18.1]



SSID: SSID of the actuator wireless network
Password: Password to log on at the actuator
IP address: The IP address of the actuator can be changed.

Info: With simultaneous operation of Wi-Fi and LAN on a PC, note that a different address is assigned for Wi-Fi. So, for example, 192.168.1.x for LAN and 192.168.2.x for Wi-Fi in order to rule out address conflicts!

3.6.19 Fieldbus [P.19]

Parameters menu for fieldbus-specific addresses and settings

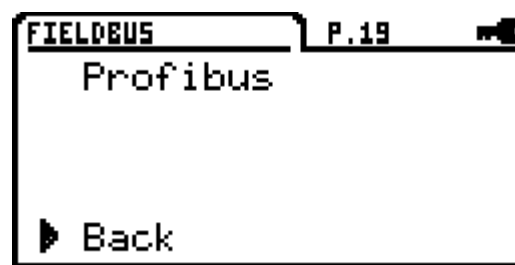

3.6.19.1 PROFIBUS [P.19.1]

Setting the PROFIBUS address 1-125



Our representatives:

Italy

PS Automazione S.r.l.
Via Pennella, 94
I-38057 Pergine Valsugana (TN)
Phone: <+39> 04 61-53 43 67
Fax: <+39> 04 61-50 48 62
E-mail: info@ps-automazione.it

India

PS Automation India Pvt. Ltd.
Srv. No. 25/1, Narhe Industrial Area,
A.P. Narhegaon, Tal. Haveli, Dist.
IND-411041 Pune
Phone: <+ 91> 20 25 47 39 66
Fax: <+ 91> 20 25 47 39 66
E-mail: sales@ps-automation.in

To find out more about all our sales partners and subsidiaries please scan the QR code below or visit our website:
<https://www.ps-automation.com/ps-automation/locations/?lang=en>



PS Automation GmbH

Philipp-Krämer-Ring 13
D-67098 Bad Dürkheim

Phone: +49 (0) 6322 94980 – 0
E-mail: info@ps-automation.com
www.ps-automation.com

