

Einbauanleitung Potentiometer PSQx03 und PSR-E-C
Installation Instructions Potentiometer PSQx03 and PSR-E-C

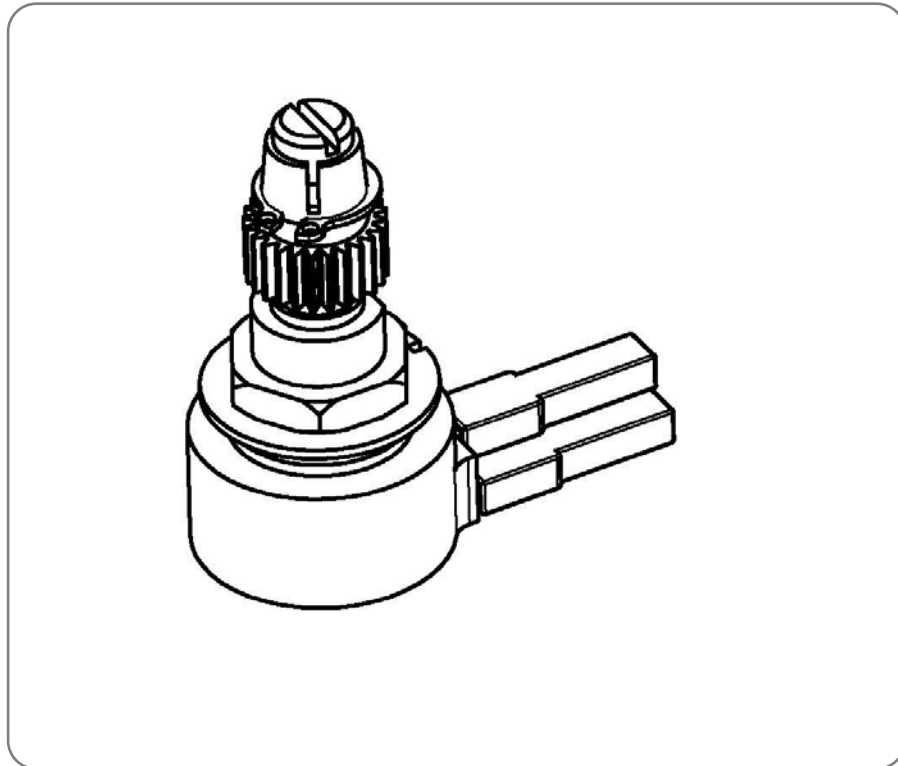

Inhaltsverzeichnis / Table of content

1. Sicherheit / *Safety*
2. Einbau / *Installation*
3. Elektrischer Anschluss Potentiometer 1 / *Wiring potentiometer 1*
4. Elektrischer Anschluss Potentiometer 2 / *Wiring potentiometer 2*
5. Anschluss am Potentiometer / *Wiring to the potentiometer*
6. Klemmenübersicht / *Terminal overview*

1. Sicherheit / Safety



Vorsicht! Lebensgefährliche elektrische Spannung kann anliegen! Sach- oder Personenschäden sind durch geeignete Maßnahmen und Einhaltung der Sicherheitsstandards zu vermeiden!

Caution! Dangerous electrical voltage can be present! Avoid personal or material damages by observing applicable regulations and safety standards!

2. Einbau / Installation

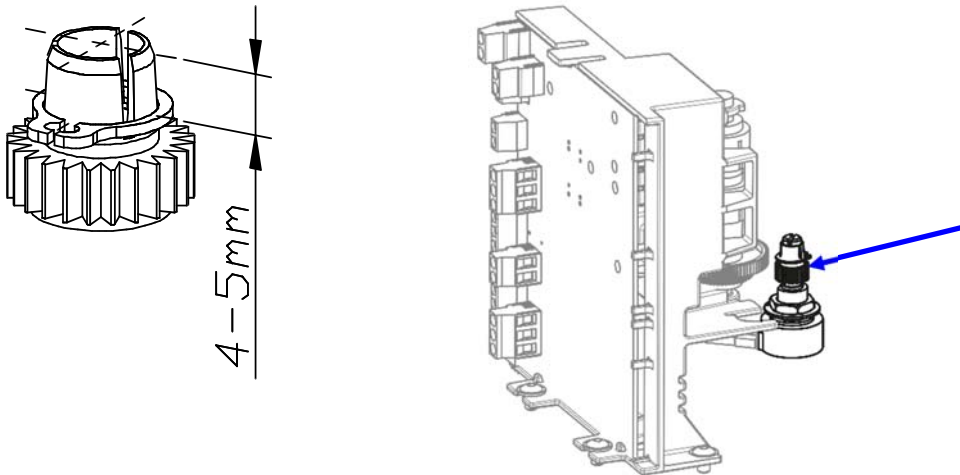

3. Elektrischer Anschluss Potentiometer 1 / Wiring potentiometer 1

Anschluss an Buchse X0 / Wiring to terminal X0

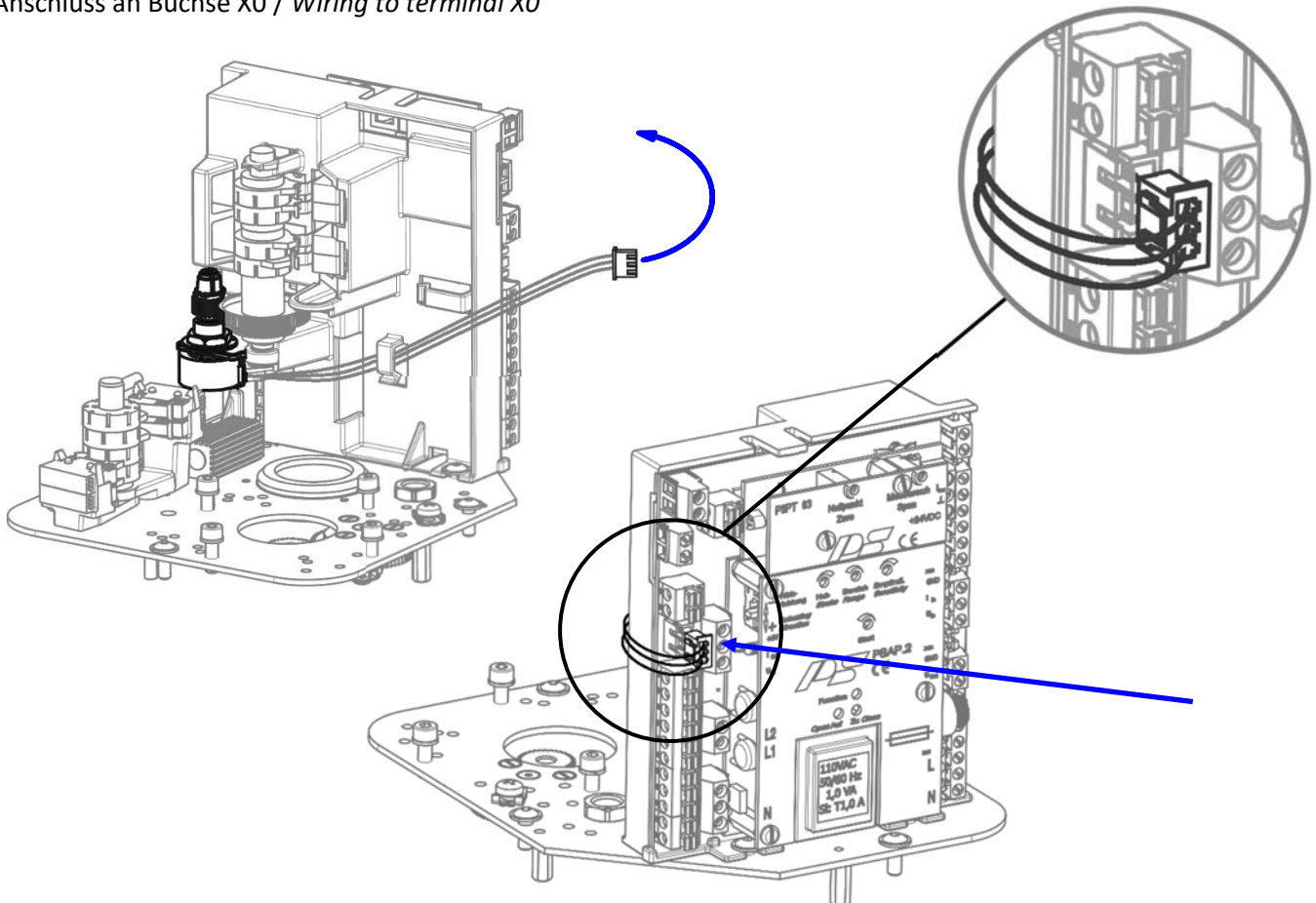

4. Elektrischer Anschluss Potentiometer 2 / *Wiring potentiometer 2*

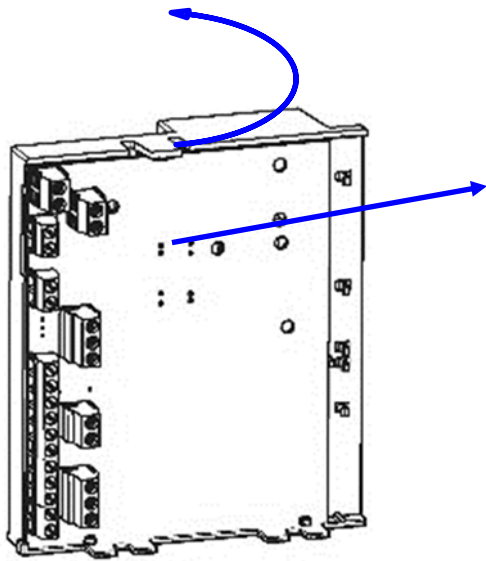

Leiterplatte lösen / *Remove PC-board*

Klemmleiste X9 einsetzen /
Insert terminal X9

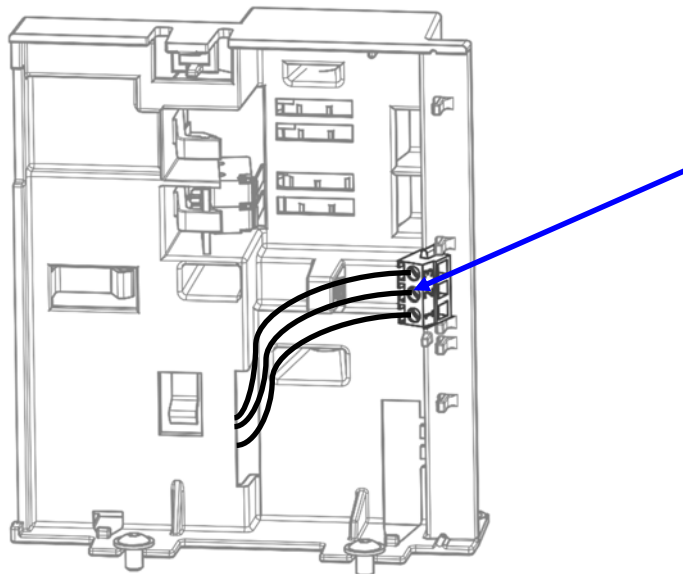

5. Anschluss am Potentiometer / *Wiring to potentiometer*

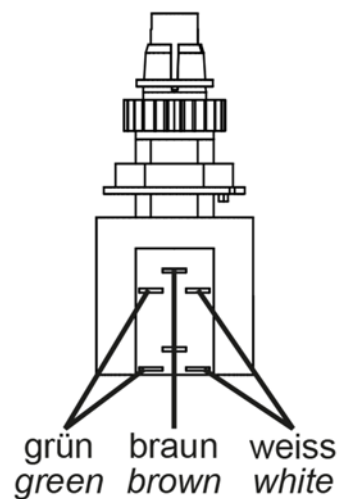
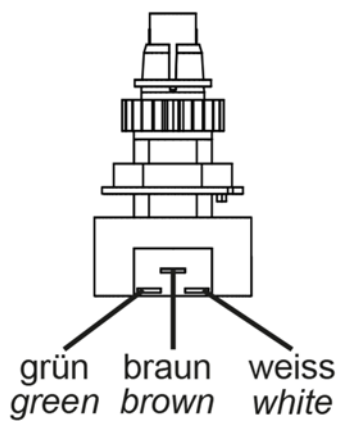

6. Klemmenübersicht / Terminal overview

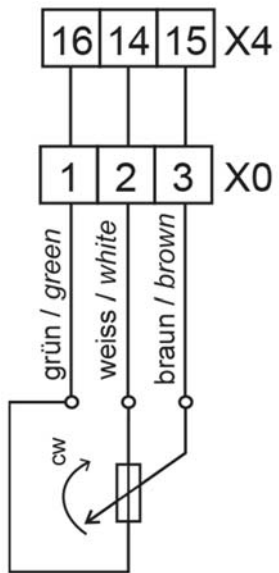
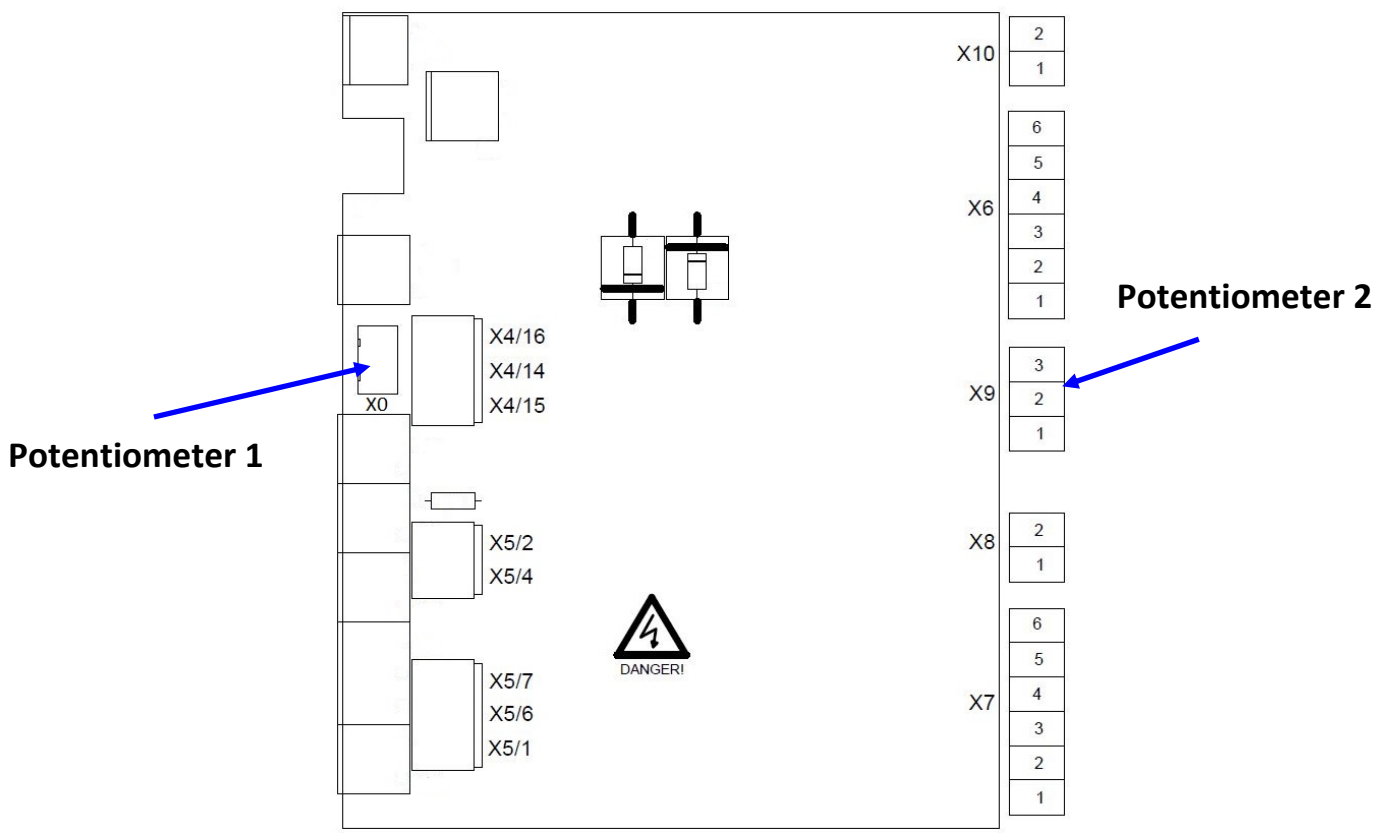

Potentiometer 1

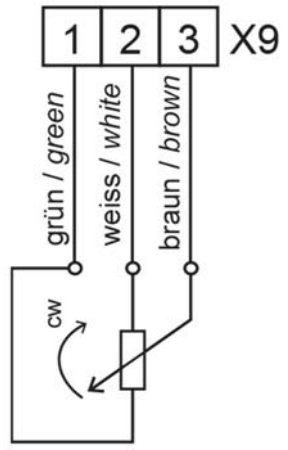

Potentiometer 2

PS Automation GmbH

Philipp-Krämer-Ring 13
D-67098 Bad Dürkheim

Phone: +49 (0) 6322 94980-0
E-mail: info@ps-automation.com
www.ps-automation.com

